

YOKE®

2024

Safety is our first priority™



Safety Components For Fall Protection





Worldwide Quality Type Approval And Certificate :

SATRA
Notified Body 0821

Issued to: Yoke Industrial Corp
#39, 33rd Road
Taichung Industrial Park
Taichung 407
Taiwan, ROC
SATRA Client: P1321

EC Type-Examination Certificate

Number 8786 Issue 2 Date first issued: 21/04/2017

This is to certify that the product group reference 'N-276' comprising the following products:

Product Reference	Description
N-276-D	Aluminium carabiner with self-closing and self-locking gate Gate opening of 22mm Static strength of 24kN
N-276	Aluminium carabiner with self-closing and self-locking gate Gate opening of 22mm Static strength of 24kN
N-276-CP	Aluminium carabiner with self-closing and self-locking gate. Includes a captive pin. Gate opening of 22mm Static strength of 24kN
N-276-TR	Aluminium carabiner with self-closing and self-locking gate Gate opening of 22mm Static strength of 24kN
N-276-TRCP	Aluminium carabiner with self-closing and self-locking gate. Includes a captive pin. Gate opening of 22mm Static strength of 24kN

Classification:
EN 362:2004 Class B

Technical reports:
SATRA: PRC0237789153536, SPC022565021429/10
DQV4: 1000008

has been subject to an EC Type-examination in accordance with Article 10 of the PPE Directive (89/686/EEC) and has been shown to satisfy the relevant provisions of this Directive for the complex category through:

- Testing to the following standard: EN 362:2004
- Examination of the relevant technical documentation.

You are therefore licensed to mark the products listed above in accordance with Article 13 of Directive (89/686/EEC) and any relevant amending Directives once you have drawn up an EC declaration of product conformity. Please note that:

- Full details of the certification and product are contained in the manufacturer's technical file
- This certificate is issued subject to the conditions on the reverse side of this certificate
- CE Marking of production is also subject to correct compliance with Directive 95/96/EEC Article 11
- Where a translation of this certificate exists, the English language version shall be conclusive as the authoritative text

Signed: Date 21/06/2017
On behalf of SATRA

CSA GROUP

Certificate of Compliance

Certificate: 1224981 Master Contract: 211822
Project: 70212011 Date Issued: 2019-02-28

Issued to: Yoke Industrial Corp
No. 39 33rd Rd
Taichung Industrial Park
Taichung, 407
TAIWAN
Attention: Connie Liu

The products listed below are eligible to bear the CSA Mark shown with adjacent indicators 'C' and 'US' for Canada and US (indicating that products have been manufactured to the requirements of both Canadian and US Standards) or with adjacent indicator 'US' for US only or without either indicator for Canada only

Issued by: Bernard Liew

PRODUCTS

CLASS - C721130 - OCCUPATIONAL HEALTH AND SAFETY PRODUCTS-Connecting Components - Fall Protection Devices

CLASS - C721131 - OCCUPATIONAL HEALTH AND SAFETY PRODUCTS-Connecting Components for PFAS-Certified to U.S. Sub-

- Classified to Standard CSA Z259.12-16, Class 7211-30; (see Note #1 for more details)
- Class 1 Snap Hooks, Model: N-3659, N-3810, N-3810-ZP, N-4250, N-3610, N-3610-ZP, N-3615, N-3615-ZP, N-3616, N-3616-ZP, N-3617, N-3617-ZP, N-3618, N-3618-ZP, N-3619, N-3710, R3003C2000, N-3626, N-3626-ZP, N-3650B, N-3615-S, N-3616-S, N-3618-S, N-3619-S, N-3660, N-4255, N-3676, N-3676-ZP, N-3610T, N-3801T, N-5271T, N-5271T-S, N-5268, N-DE360, N-910205, N-210191, N-2000210, N-2000209, N-3620T, N-3633T, N-3620T-ZP, N-3633T-ZP, N-3630T, N-3801-ZP, N-5271T, N-3680

DNV-GL

MANAGEMENT SYSTEM CERTIFICATE

Yoke Industrial Corp.

No. 39, 33rd Road, Taichung Industrial Park, Taichung, Taiwan, 407 and the sites as mentioned in the appendix accompanying this certificate

has been found to conform to the Quality Management System standard: **ISO 9001:2015**

This certificate is valid for the following scope:

Design, Development and Manufacturing of Grade 80/100 Chain Sling Systems, including Chains, Fittings for Chains, Wire Ropes and Web Slings, Shackles, Snatch Blocks, Swivel Blocks, Turnbuckles, Wire Rope Clevis, Used in Offshore, Construction, Material Handling and Mining and Safety Components for Personal Safety Purposes, Design, Development and Manufacturing of Shearers for Drilling and Production Hoisting Equipment

Issue and Validity:
Issued: 04 March 2019

For further information:
DNV GL - Business Assistance
Data & Marketing & Product Management
DNV GL - Quality Management
DNV GL - Certification & Registration
Tel: +47 63 2178800

QMS REGISTERED

Certificate of Registration

APIQ® REGISTRATION NUMBER 0726

This certifies that the quality management system of Yoke Industrial Corp., No. 39, 33rd Road, Taichung Industrial Park, Taichung, Taiwan, Republic of China

has been assessed by the American Petroleum Institute Quality Register (APIQ®) and found to be in conformance with the following standard:

ISO 9001:2015

The scope of this registration and the approved quality management system applies to the Design and Manufacture of Swage and Spelter Sockets, Shackles, Snatch Blocks, Grade 8/10 Chain Fittings for Chain, Wire Ropes and Webbing Slings for Material Handling System and Safety Components for Personal Safety Purposes

APIQ® approves the organization's justification for excluding:
No Exclusions Identified as Applicable

Effective Date: JUNE 22, 2018
Expiration Date: MARCH 30, 2021
Registered Since: JUNE 22, 2018

Executive Vice President

API REGISTRATION NO. Q1-0467

Certificate of Registration

The American Petroleum Institute certifies that the quality management system of Yoke Industrial Corp., No. 39, 33rd Road, Taichung Industrial Park, Taichung, Taiwan, Republic of China

has been assessed by the American Petroleum Institute and found to be in conformance with the following:

API Specification Q1

The scope of this registration and the approved quality management system applies to the Design and Manufacture of Swage and Spelter Sockets, Shackles, Snatch Blocks, Grade 8/10 Chain Fittings for Chain, Wire Ropes and Webbing Slings for Material Handling System and Safety Components for Personal Safety Purposes

API approves the organization's justification for excluding:
Servicing

Effective Date: JUNE 22, 2018
Expiration Date: MARCH 30, 2021
Registered Since: AUGUST 27, 2007

Executive Vice President

Rope Snaps
Rebar Hooks



D Rings
Buckles
Adjusters



Dielectric
Components



Aluminum alloy
& Stainless Steel
Components



Steel &
Aluminum alloy
Carabiners



Rope Grabs



Miscellaneous



Integrated RFID
Hardware



Safety is our first priority™
- Quality, Reliability, Innovation -



Strict Manufacturing, Quality Control, and Testing



YOKE operates a consistent production facility with quality control at every manufacturing stage. From raw materials to the completed product, **YOKE's** quality meets or exceeds ANSI, CSA and EN specifications.

YOKE is an ISO 9001 certified company and has Type Approval and audit program with CSA Group Testing & Certification Inc. (Canada) and SATRA Technology Centre Ltd. (England).

Test Certificates are included with every shipment from **YOKE**. These certificates are your assurance of unsurpassed quality.

● Spectrographic Analysis :

Ensure proper metallurgy content of all raw materials.

● Proof Load Testing :

All safety harness connecting components are 100% proof loaded to 3600 lbs / 16 kN.

● Ultimate Breaking Load Test :

Connecting and adjusting components are batch tested for ultimate breaking strength.

- connecting components - exceed 5000 lbs
- adjusting components - exceed 4000 lbs

Certificate of Conformance



Year of manufacture & batch code links to Certificate of Conformance

Forged

PT: proof load tested

Warning on the gate

Item Number

Y : Manufacturer (YOKE)
5M : 5000 lbs minimum tensile strength.



WARNING

YOKE HARDWARE IN THIS CATALOGUE IS DESIGNED FOR PERSONAL FALL PROTECTION AND IS **NOT TO BE USED FOR MATERIAL HANDLING**



COMPLETE RANGE OF ANSI/CSA CONNECTORS

The ANSI/CSA standard requires connectors with an integral eye to have gate strength (side and face) of 3600 lbs.

It also requires connectors without an integral eye to have all around gate strength of 3600 lbs (side, face and minor axis).

YOKE offers a full range of these ANSI/CSA compliant connectors:

- Snap Hooks
- Swivel Hooks
- Clevis Snap Hooks
- Indicator Swivel Hooks
- Rebar Hooks
- Swivel Rebar Hooks
- Pole Strap Snap Hooks
- Aluminum Rebar Hooks
- Aluminum Snap Hooks

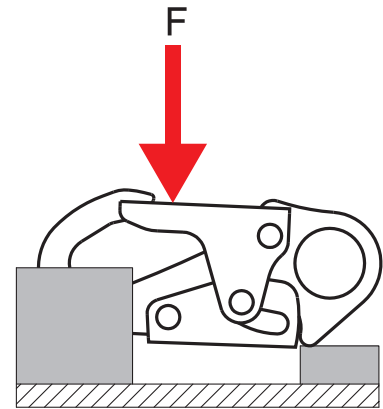

Gate face resistance test

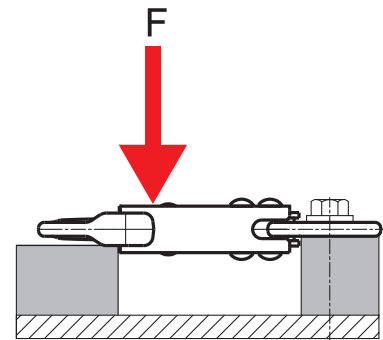

Gate side-load resistance test

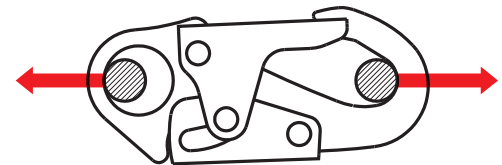

Major axis test



N-3610

**Rope Snap Hook
3600 LBS gate strength**

Forged steel, heat treated
100% proof loaded to 3600 lbs / 16 kN
Min. Breaking load : 5000 lbs / 23 kN
Meets :

- ANSI Z359.12-2019
- CSA Z259.12-16
- EN 362 : 2004

Net weight : 13.6 oz. / 388 g
Zinc Plated

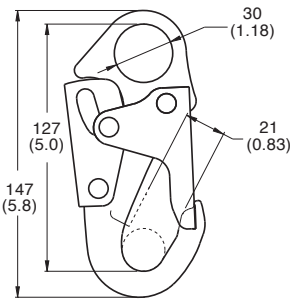

mm (inch)

N-3810

**Stamped Rope Snap Hook
3600 LBS gate strength**

Sheet steel, heat treated
100% proof loaded to 3600 lbs / 16 kN
Min. Breaking load : 5000 lbs / 23 kN
Meets :

- ANSI Z359.12-2019
- CSA Z259.12-16
- EN 362 : 2004

Net weight : 12.7 oz. / 362 g
Zinc Plated

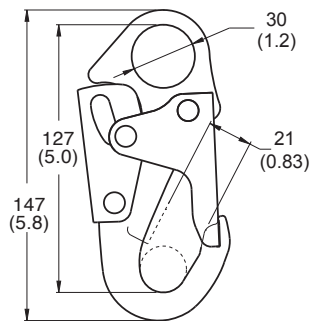

mm (inch)

N-3810X

**Stamped Rope Snap Hook
3600 LBS gate strength**

Sheet steel, heat treated
100% proof loaded to 3600 lbs / 16 kN
Min. Breaking load : 5000 lbs / 23 kN
Meets :

- ANSI Z359.12-2019
- CSA Z259.12-16
- EN 362 : 2004

Net weight : 10.6 oz. / 304 g
Zinc Plated

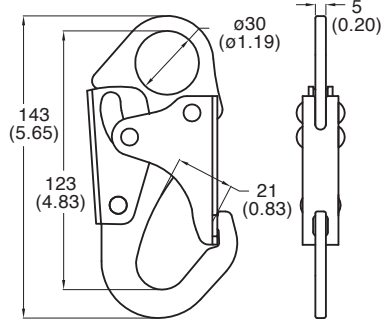

mm (inch)

N-3710

**Rope Snap Hook
3600 LBS gate strength**

Forged steel, heat treated
100% proof loaded to 3600 lbs / 16 kN
Min. Breaking load : 5000 lbs / 23 kN
Meets :

- ANSI Z359.12-2019
- CSA Z259.12-16
- EN 362 : 2004

Net weight : 11.7 oz. / 332 g
Zinc Plated

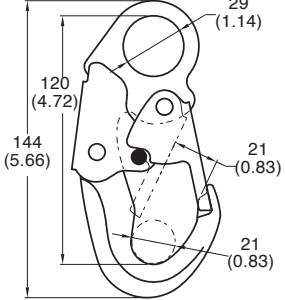

mm (inch)

N-3615
Indicator Swivel Hook
3600 LBS gate strength

Forged steel, heat treated
 100% proof loaded to 3600 lbs / 16 kN
 Min. Breaking load : 5000 lbs / 23 kN
 Meets :
 ● ANSI Z359.12-2019
 ● CSA Z259.12-16
 ● EN 362 : 2004
 Net weight : 17.5 oz. / 501 g
 Indicator Strength Options: ① 500 lbs ② 750 lbs
Zinc Plated

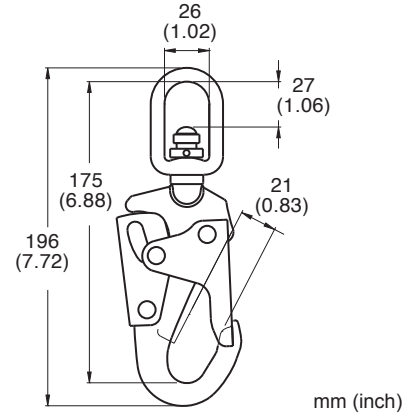
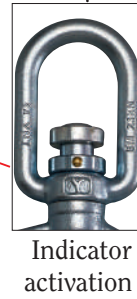

N-3616
Swivel Hook
3600 LBS gate strength
(non-Indicator)

Forged steel, heat treated
 100% proof loaded to 3600 lbs / 16 kN
 Min. Breaking load : 5000 lbs / 23 kN
 Meets :
 ● ANSI Z359.12-2019
 ● CSA Z259.12-16
 ● EN 362 : 2004
 Net weight : 17.2 oz. / 490 g
Zinc plated

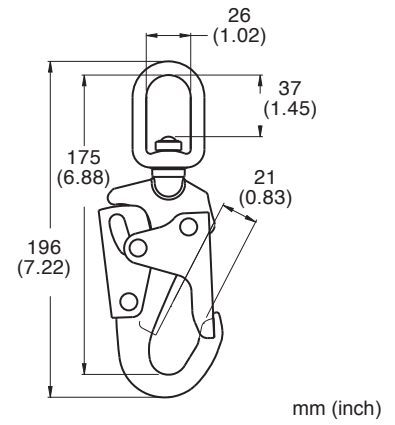

N-3617
Clevis Snap Hook
3600 LBS gate strength

Forged steel, heat treated
 100% proof loaded to 3600 lbs / 16 kN
 Min. Breaking load : 5000 lbs / 23 kN
 Meets :
 ● ANSI Z359.12-2019
 ● CSA Z259.12-16
 ● EN 362 : 2004
 Net weight : 14.0 oz. / 398 g
Zinc Plated

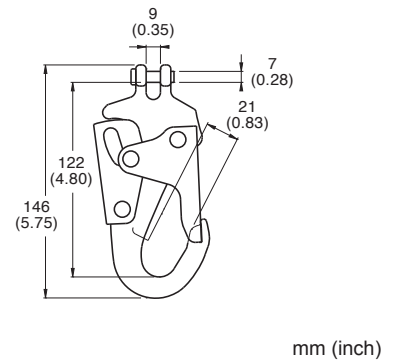

N-3618
Tie Back Snap Hook
5000 LBS gate strength

Forged steel, heat treated
 100% proof loaded to 3600 lbs / 16 kN
 Min. Breaking load : 5000 lbs / 23 kN
 Meets :
 ● ANSI Z359.12-2019
 ● CSA Z259.12-16
 ● EN 362 : 2004
 Net weight : 16.0 oz. / 454 g
Zinc Plated

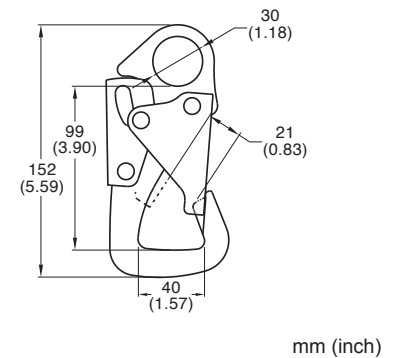

N-3658

Pole Strap Snap Hook
3600 LBS gate strength

Forged steel, heat treated
100% proof loaded to 3600 lbs / 16 kN
Min. Breaking load : 5000 lbs / 23 kN

- Meets :
- ANSI Z359.12-2019
 - CSA Z259.12-16
 - EN 362 : 2004

Net weight : 17.8 oz. / 506 g

Zinc Plated

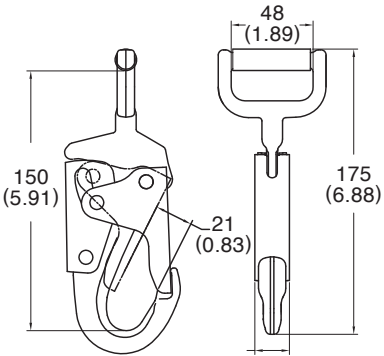

mm (inch)

N-3660

Spreader Snap Hook
3600 LBS gate strength

Forged steel, heat treated
100% proof loaded to 3600 lbs / 16 kN
Min. Breaking load : 5000 lbs / 23 kN

- Meets :
- ANSI Z359.12-2019
 - CSA Z259.12-16
 - EN 362 : 2004

Net weight : 25.4 oz. / 728 g

Zinc Plated

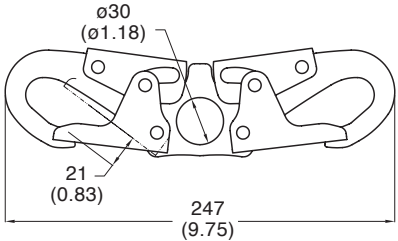

mm (inch)

N-RCT27337

Rebar Chain Assembly

Rebar Hook Gate Opening : 2.55 inch / 64.77 mm
Snap Hook Gate Opening : 0.83 inch / 21.08 mm
Length : 27inch / 685.8 mm
Net weight : 74.1 oz. / 2.1 kg

Zinc Plated



**N-3032
Snap Hook**

Forged steel, heat treated
 Min. Breaking load : 5000 lbs / 23 kN
 Meets :
 ● EN 362 : 2004
 Net weight : 10.6 oz. / 303 g

Zinc Plated

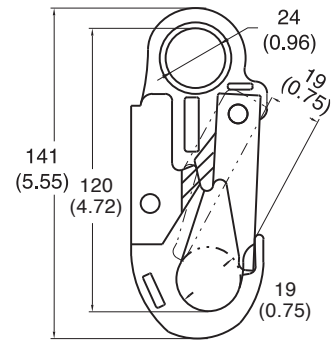

mm (inch)

**N-315
Stamped Snap Hook**

Sheet steel, heat treated
 Min. Breaking load : 5000 lbs / 23 kN
 Meets :
 ● EN 362 : 2004
 Net weight : 8.4 oz. / 239 g

Zinc Plated

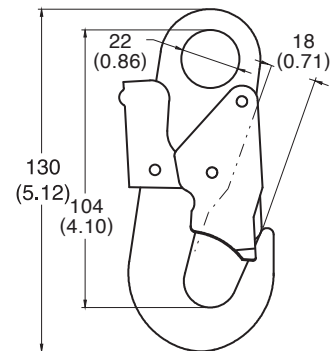

mm (inch)

**N-315X
Stamped Snap Hook**

Sheet steel, heat treated
 Min. Breaking load : 5000 lbs / 23 kN
 Meets :
 ● EN362 : 2004
 Net weight : 7.1 oz. / 200 g

Zinc Plated

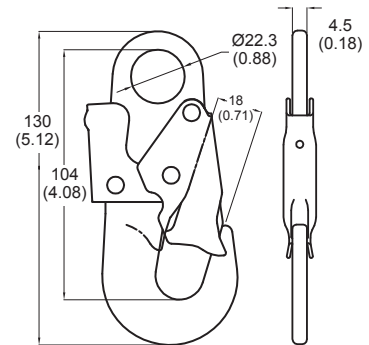

mm (inch)

**N-306
Stamped Snap Hook**

Sheet steel, heat treated
 Min. Breaking load : 5000 lbs / 23 kN
 Meets :
 ● EN 362 : 2004
 Net weight : 9.7 oz. / 275 g

Zinc Plated

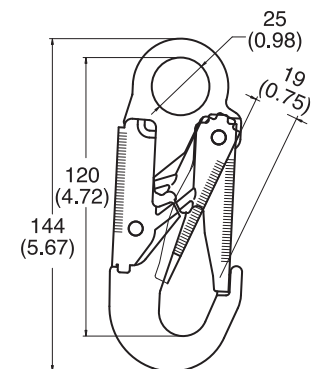
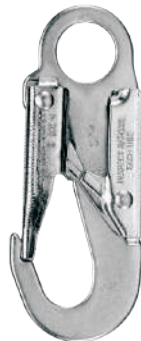

mm (inch)

N-3035
Indicator Swivel Snap Hook

Forged steel, heat treated
Min. Breaking load : 5000 lbs / 23 kN
Meets :
● EN 362 : 2004
Net weight : 13.9 oz. / 394 g

Zinc Plated



Indicator activation

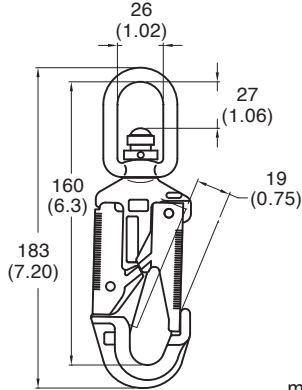

mm (inch)

N-3035 / 0
Swivel Snap Hook
(non - Indicator)

Forged steel, heat treated
Min. Breaking load : 5000 lbs / 23 kN
Meets :
● EN 362 : 2004
Net weight : 12.9 oz. / 366 g

Zinc Plated

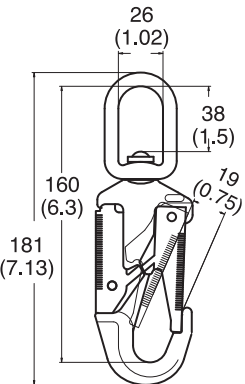

mm (inch)

N-3167
Indicator Swivel Snap Hook

Forged steel, heat treated
Min. Breaking load : 5000 lbs / 23 kN
Meets :
● EN 362 : 2004
Net weight : 13.2 oz. / 377 g

Zinc Plated

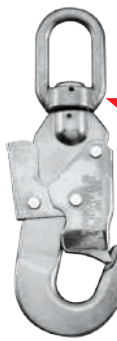

Indicator activation

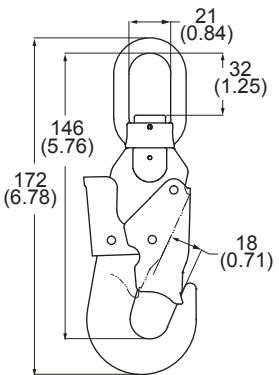

mm (inch)

N-3167 / 0
Swivel Snap Hook
(non - Indicator)

Forged steel, heat treated
Min. Breaking load : 5000 lbs / 23 kN
Meets :
● EN 362 : 2004
Net weight : 12.9 oz. / 368 g

Zinc Plated

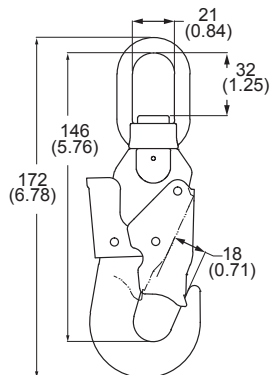

mm (inch)

N-3033

Snap Hook

Forged steel, heat treated
 Min. Breaking load : 5000 lbs / 23 kN
 Meets :
 ● EN 362 : 2004
 Net weight : 9.7 oz. / 276 g

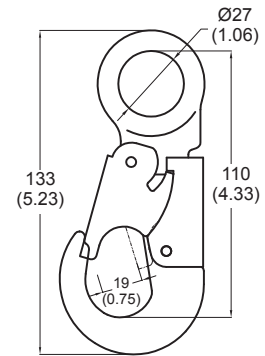

mm (inch)

Zinc Plated

N-3056

Stamped Snap Hook

Sheet steel, heat treated
 Min. Breaking load : 5000 lbs / 23 kN
 Meets :
 ● EN 362 : 2004
 Net weight : 9.0 oz. / 256 g

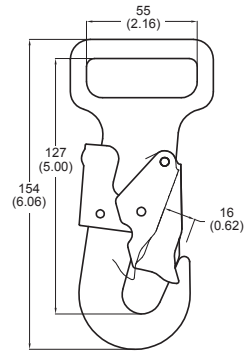

mm (inch)

Zinc Plated

N-3039

Adjustable Slide Pole Hook

Forged steel, heat treated
 Min. Breaking load : 5000 lbs / 23 kN
 Net weight : 6.0 oz. / 170 g

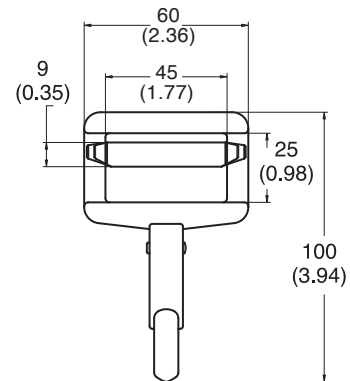

mm (inch)

Zinc Plated

N-3040

Pole Strap Snap Hook

Forged steel, heat treated
 Min. Breaking load : 5000 lbs / 23 kN
 Net weight : 4.1 oz. / 115 g

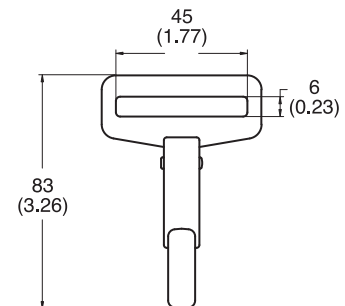

mm (inch)

Zinc Plated

N-3040-1
Pole Strap Snap Hook
With Wing Keeper

Forged steel, heat treated
Min. Breaking load : 5000 lbs / 23 kN
Net weight : 4.0 oz. / 115 g

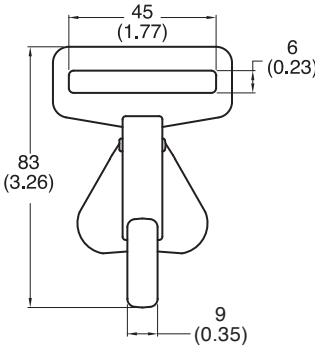

Zinc Plated

mm (inch)

N-3041
Pole Strap Snap Hook
With Wing Keeper

Forged steel, heat treated
Min. Breaking load : 5000 lbs / 23 kN
Net weight : 10.9 oz. / 310 g

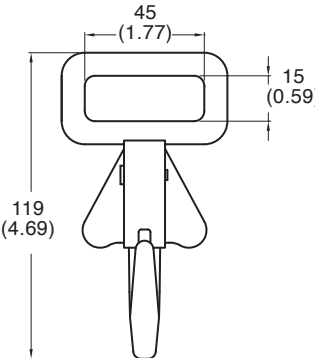

Zinc Plated

mm (inch)

N-3058
Pole Strap Snap Hook

Forged steel, heat treated
Min. Breaking load : 5000 lbs / 23 kN
Meets :
● EN 362 : 2004
Net weight : 14.1 oz. / 396 g

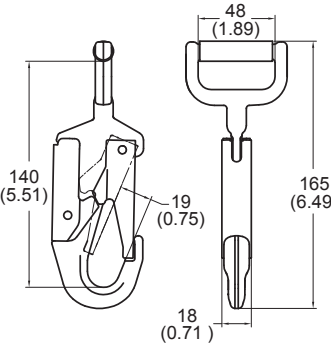

Zinc Plated

mm (inch)

N-3059
Pole Strap Snap Hook

Forged steel, heat treated
Min. Breaking load : 5000 lbs / 23 kN
Meets :
● EN 362 : 2004
Net weight : 15.5 oz. / 454 g

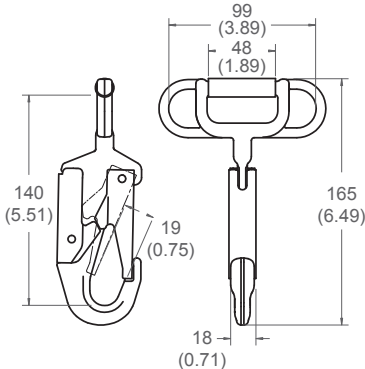

Zinc Plated

mm (inch)

**N-3049
Safety Pole Strap Snap**

Forged steel, heat treated
 Min. Breaking load : 5000 lbs / 23 kN
 Net weight : 11.4 oz. / 324 g

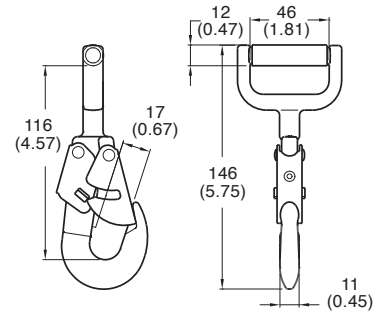

Zinc Plated

mm (inch)

**N-3036
Clevis Snap Hook**

Forged steel, heat treated
 Min. Breaking load : 5000 lbs / 23 kN
 Meets :
 ● EN 362 : 2004
 Net weight : 11.5 oz. / 328 g

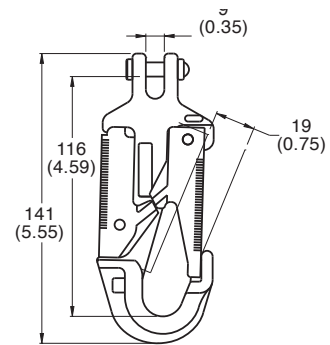

Zinc Plated

mm (inch)

**N-3155
Stamped Snap Hook**

Sheet steel, heat treated
 Min. Breaking load : 5000 lbs / 23 kN
 Meets :
 ● EN 362 : 2004
 Net weight : 8.8 oz. / 250 g

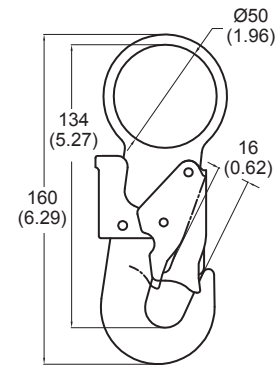

Zinc Plated

mm (inch)

**N-3161
Rope Snap Hook**

Forged steel, heat treated
 Min. Breaking load : 5000 lbs / 23 kN
 Meets :
 ● EN 362 : 2004
 Net weight : 9.4 oz. / 268 g

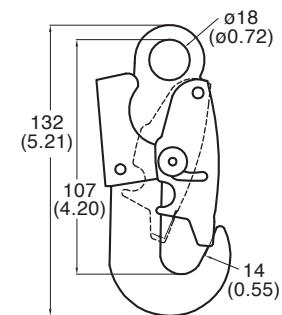

Zinc Plated

mm (inch)

N-3630T
Rebar Hook
3600 LBS gate / Transverse Load

Forged steel, heat treated
 100% proof loaded to 3600 lbs / 16 kN
 Min. Breaking load : 5000 lbs / 23 kN
 Meets :
 ● ANSI Z359.12-2019
 ● CSA Z259.12-16
 ● EN 362 : 2004
 Net weight : 28.5 oz. / 800 g

Zinc Plated

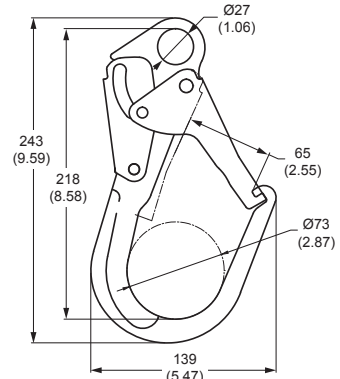

mm (inch)

N-3630TF
Rebar Hook
3600 LBS gate / Transverse Load

Forged steel, heat treated
 100% proof loaded to 3600 lbs / 16 kN
 Min. Breaking load : 5000 lbs / 23 kN
 Meets :
 ● ANSI Z359.12-2019
 ● CSA Z259.12-16
 ● EN 362 : 2004
 Net weight : 25.8 oz. / 732 g

Zinc Plated

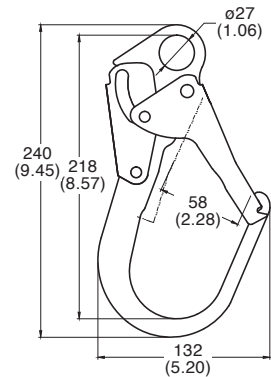

mm (inch)

N-3830T
Stamped Rebar Hook
3600 LBS gate / Transverse Load

Sheet steel, heat treated
 100% proof loaded to 3600 lbs / 16 kN
 Min. Breaking load : 5000 lbs / 23 kN
 Meets :
 ● ANSI Z359.12-2019
 ● CSA Z259.12-16
 ● EN 362 : 2004
 Net weight : 26.3 oz. / 752 g

Zinc Plated

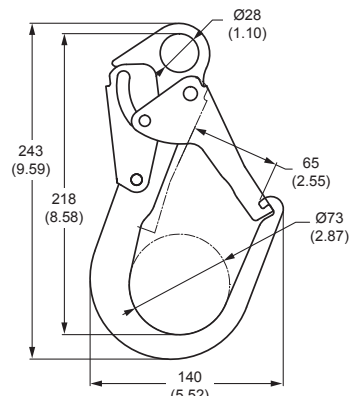

mm (inch)

N-3633T
Indicator Swivel Rebar Hook
3600 LBS gate / Transverse Load

Forged steel, heat treated
 100% proof loaded to 3600 lbs / 16kN
 Min. Breaking load : 5000 lbs / 23 kN
 Meets :
 ● ANSI Z359.12-2019
 ● CSA Z259.12-16
 ● EN 362 : 2004
 Net weight : 30.21 oz. / 823 g

Zinc Plated



Indicator activation

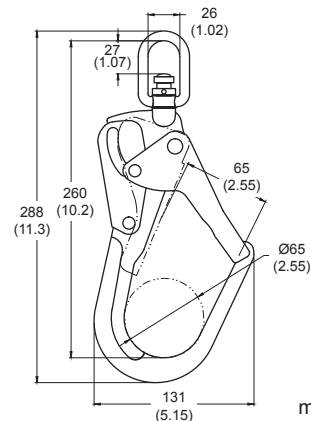

mm (inch)

N-3633TF/0
Swivel Rebar Hook
3600 LBS gate / Transverse Load
(non-Indicator)

Forged steel, heat treated
 100% proof loaded to 3600 lbs / 16 kN
 Min. Breaking load : 5000 lbs / 23 kN
 Meets :
 ● ANSI Z359.12-2019
 ● CSA Z259.12-16
 ● EN 362 : 2004
 Net weight : 28.9 oz. / 820 g
Zinc Plated

New

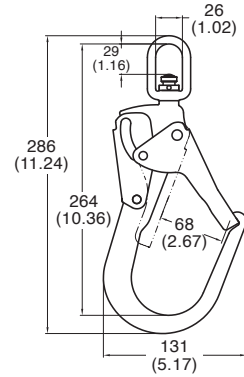

mm (inch)

N-3633T / 0
Swivel Rebar Hook
3600 LBS gate / Transverse Load
(non - Indicator)

Forged steel, heat treated
 100% proof loaded to 3600 lbs / 16kN
 Min. Breaking load : 5000 lbs / 23 kN
 Meets :
 ● ANSI Z359.12-2019
 ● CSA Z259.12-16
 ● EN 362 : 2004
 Net weight : 30.21 oz. / 823 g
Zinc Plated

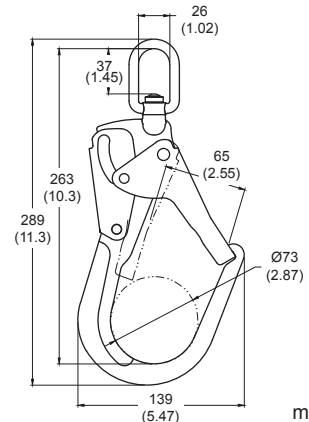

mm (inch)

N-3620T
Ladder Hook
3600 LBS gate / Transverse Load

Forged steel, heat treated
 100% proof loaded to 3600 lbs / 16 kN
 Min. Breaking load : 5000 lbs / 23 kN
 Meets :
 ● ANSI Z359.12-2019
 ● CSA Z259.12-16
 ● EN 362 : 2004
 Net weight : 17.99 oz. / 514 g
Zinc Plated

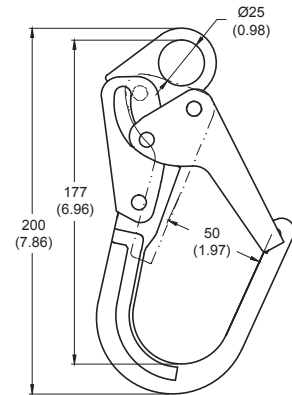

mm (inch)

N-3625T
Indicator Swivel Ladder Hook
3600 LBS gate / Transverse Load

Forged steel, heat treated
 100% proof loaded to 3600 lbs / 16 kN
 Min. Breaking load : 5000 lbs / 23 kN
 Meets :
 ● ANSI Z359.12-2019
 ● CSA Z259.12-16
 ● EN 362 : 2004
 Net weight : 22.5 oz. / 638 g
Zinc Plated

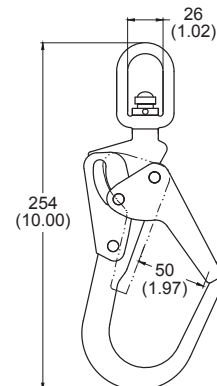
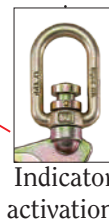

mm (inch)

N-3625T / 0
Swivel Ladder Hook
3600 LBS gate / Transverse Load
(non - Indicator)

Forged steel, heat treated
 100% proof loaded to 3600 lbs / 16kN
 Min. Breaking load : 5000 lbs / 23 kN
 Meets :
 ● ANSI Z359.12-2019
 ● CSA Z259.12-16
 ● EN 362 : 2004
 Net weight : 22.86 oz. / 648 g
Zinc Plated

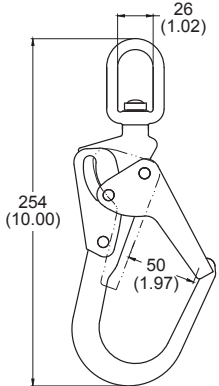

mm (inch)

N-3680
Rebar Hook
3600 LBS gate / Transverse Load

Sheet steel, heat treated
 100% proof loaded to 3600 lbs / 16 kN
 Min. Breaking load : 5000 lbs / 23 kN
 Meets :
 ● ANSI Z359.12-2019
 ● CSA Z259.12-16
 ● EN 362 : 2004
 Net weight : 34.7 oz. / 984g
Zinc Plated

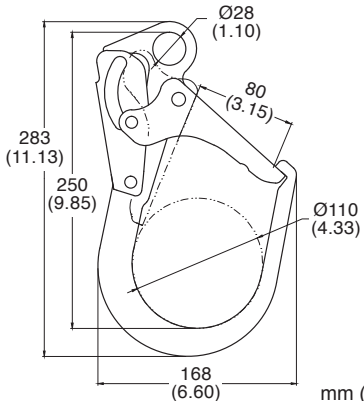

mm (inch)

N-314-MX
Rebar Hook
Designed for 2" or small rebar

Forged steel, heat treated
 Min. Breaking load : 5000 lbs / 23 kN
 Meets :
 ● EN 362 : 2004
 Net weight : 17.6 oz. / 500 g

Part Number	Finish
N-314-ZP	Zinc plated, Polished
N-314-MX	Zinc plated, Matte
N-314-YW	Yellow Zinc plated, Matte

Zinc Plated

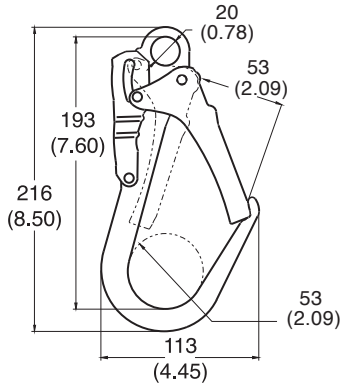

mm (inch)

N-326
Rebar Hook
Designed for 2-1 / 4" rebar

Forged steel, heat treated
 Min. Breaking load : 5000 lbs / 23 kN
 Meets :
 ● EN 362 : 2004
 Net weight : 20.6 oz. / 594 g

Zinc Plated

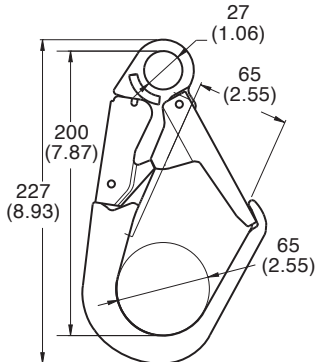

mm (inch)

N-325 / 0
Swivel Rebar Hook
Designed for 2-1 / 4" rebar
(non-indicator)

Forged steel, heat treated
 Min. Breaking load : 5000 lbs / 23 kN
 Meets :
 ● EN 362 : 2004
 Net weight : 24.0 oz. / 680 g

Zinc Plated

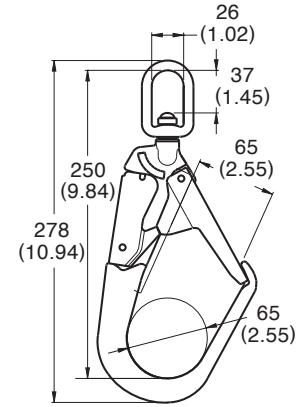
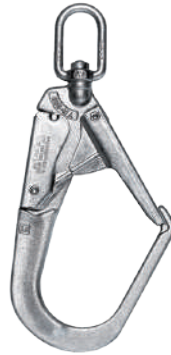

mm (inch)

N-360
Large Capacity Rebar Hook

Steel, heat treated
 Min. breaking load : 5000 lbs / 23 kN
 Meets :
 ● EN 362 : 2004
 Net weight : 29.8 oz. / 846 g

Zinc Plated

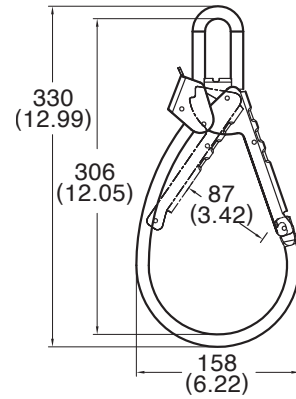

mm (inch)



**N-416L
D-Ring**

Forged steel, heat treated
 100% proof loaded to 3600 lbs / 16 kN
 Min. Breaking load : 5000 lbs / 23 kN
 Meets :
 ● ANSI Z359.12-2019
 ● CSA Z259.12-16
 Net weight : 4.2 oz. / 120 g

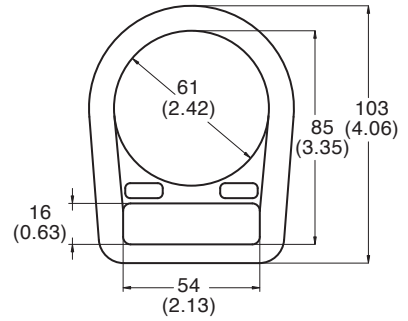

Zinc Plated

Light Weight Design

mm (inch)

**N-416L-R
Roller D-Ring**

Forged steel, heat treated
 100% proof loaded to 3600 lbs / 16 kN
 Min. Breaking load : 5000 lbs / 23 kN
 Meets :
 ● ANSI Z359.12-2019
 ● CSA Z259.12-16
 Net weight : 4.3 oz. / 122 g

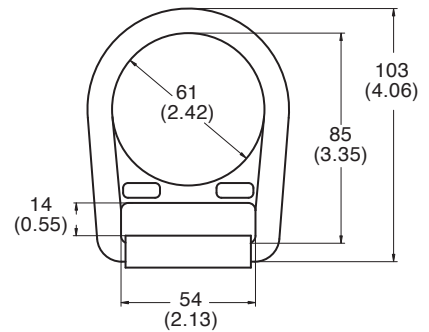
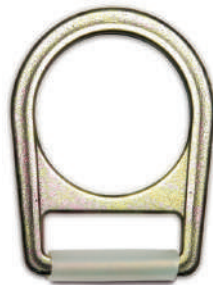

Zinc Plated

Light Weight Design

mm (inch)

**N-416
D-Ring**

Forged steel, heat treated
 100% proof loaded to 3600 lbs / 16 kN
 Min. Breaking load : 5000 lbs / 23 kN
 Meets :
 ● ANSI Z359.12-2019
 ● CSA Z259.12-16
 Net weight : 5.0 oz. / 142 g

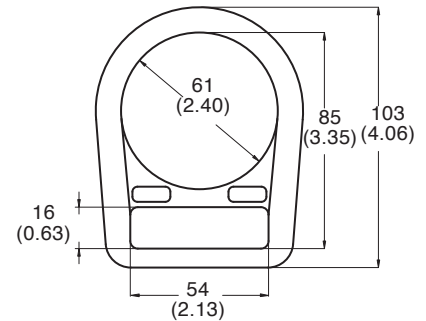

Zinc Plated

mm (inch)

**N-416R
Roller D-Ring**

Forged steel, heat treated
 100% proof loaded to 3600 lbs / 16 kN
 Min. Breaking load : 5000 lbs / 23 kN
 Meets :
 ● ANSI Z359.12-2019
 ● CSA Z259.12-16
 Net weight : 5.1 oz. / 146 g

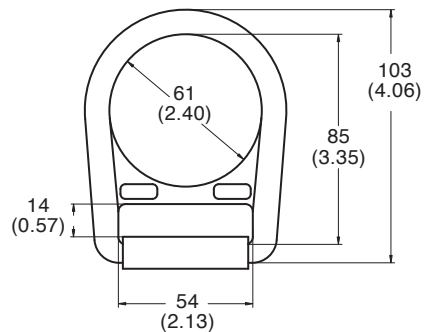

Zinc Plated

mm (inch)

**N-414
D-Ring**

Forged steel, heat treated
 100% proof loaded to 3600 lbs / 16 kN
 Min. Breaking load : 5000 lbs / 23 kN
 Meets :
 ● ANSI Z359.12-2019
 ● CSA Z259.12-16
 Net weight : 5.1 oz. / 145 g

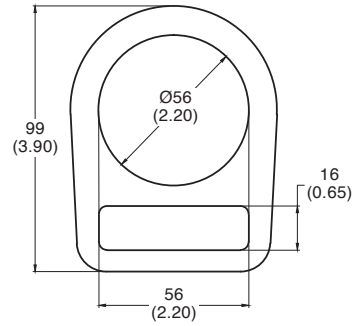

mm (inch)

Zinc Plated

**N-414X
D Ring**

Sheet steel, heat treated
 100% proof loaded to 3600 lbs / 16 kN
 Min. Breaking load : 5000 lbs / 23 kN
 Meets :
 ● ANSI Z359.12-2019
 ● CSA Z259.12-16
 Net weight : 4.1 oz. / 117 g

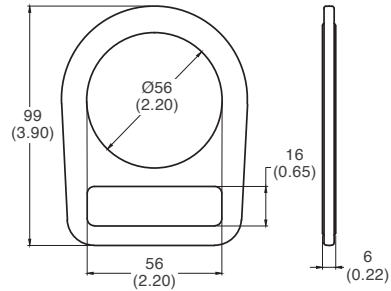
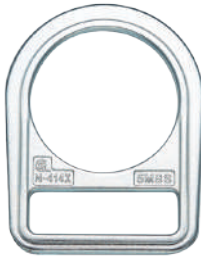

mm (inch)

Zinc Plated

**N-414R
Roller D-Ring**

Forged steel, heat treated
 100% proof loaded to 3600 lbs / 16 kN
 Min. Breaking load : 5000 lbs / 23 kN
 Meets :
 ● ANSI Z359.12-2019
 ● CSA Z259.12-16
 Net weight : 5.2 oz. / 149 g

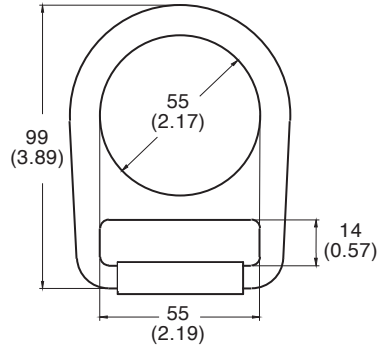

mm (inch)

Zinc Plated

**N-409
D-Ring**

Forged steel, heat treated
 100% proof loaded to 3600 lbs / 16 kN
 Min. Breaking load : 5000 lbs / 23 kN
 Meets :
 ● ANSI Z359.12-2019
 ● CSA Z259.12-16
 Net weight : 8.4 oz. / 228 g

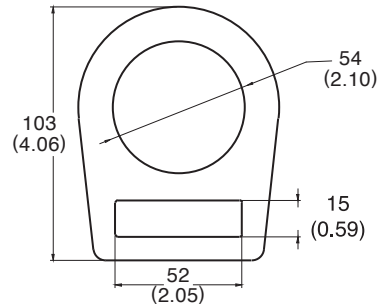

mm (inch)

Zinc Plated

**N-418
D-Ring**

Forged steel, heat treated
 100% proof loaded to 3600 lbs / 16 kN
 Min. Breaking load : 5000 lbs / 23 kN
 Meets :
 ● ANSI Z359.12-2019
 ● CSA Z259.12-16
 Net weight : 3.8 oz. / 112 g

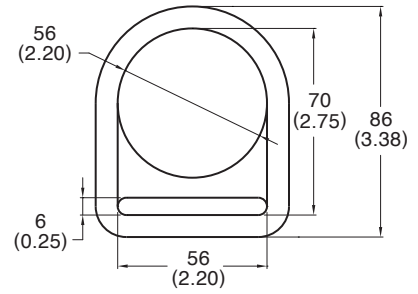

Zinc Plated

mm (inch)

**N-415
Stamped D-Ring**

Sheet steel, heat treated
 100% proof loaded to 3600 lbs / 16 kN
 Min. Breaking load : 5000 lbs / 23 kN
 Meets :
 ● ANSI Z359.12-2019
 ● CSA Z259.12-16
 Net weight : 5.0 oz. / 142 g

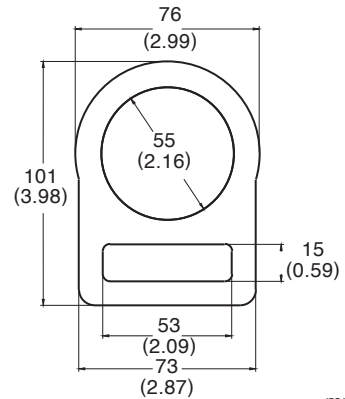
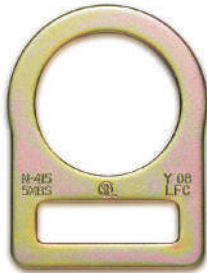

Zinc Plated

mm (inch)

**N-415R
Roller Stamped D-Ring**

Sheet steel, heat treated
 100% proof loaded to 3600 lbs / 16 kN
 Min. Breaking load : 5000 lbs / 23 kN
 Meets :
 ● ANSI Z359.12-2019
 ● CSA Z259.12-16
 Net weight : 5.1 oz. / 145 g

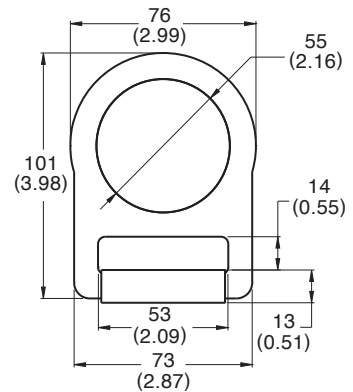
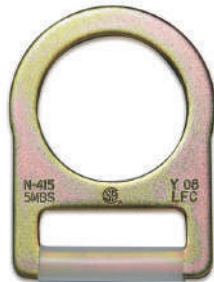

Zinc Plated

mm (inch)

**N-415X
Stamped D-Ring**

Sheet steel, heat treated
 100% proof loaded to 3600 lbs / 16 kN
 Min. Breaking load : 5000 lbs / 23 kN
 Meets :
 ● ANSI Z359.12-2019
 ● CSA Z259.12-16
 Net weight : 3.5 oz. / 100 g

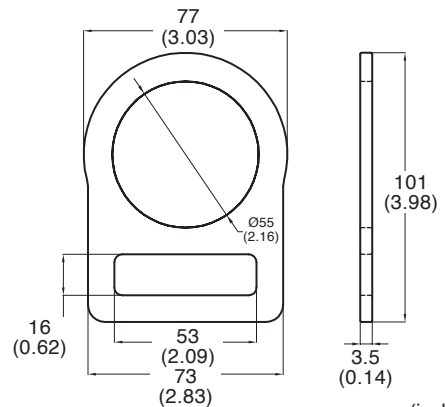
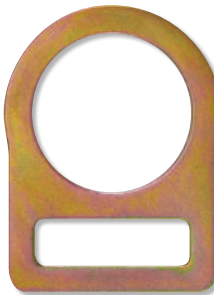

Zinc Plated

mm (inch)

**N-419
Stamped D-Ring**

Sheet steel, heat treated
 100% proof loaded to 3600 lbs / 16 kN
 Min. Breaking load : 5000 lbs / 23 kN
 Meets :
 ● ANSI Z359.12-2019
 ● CSA Z259.12-16
 Net weight : 4.8 oz. / 136 g

Zinc Plated

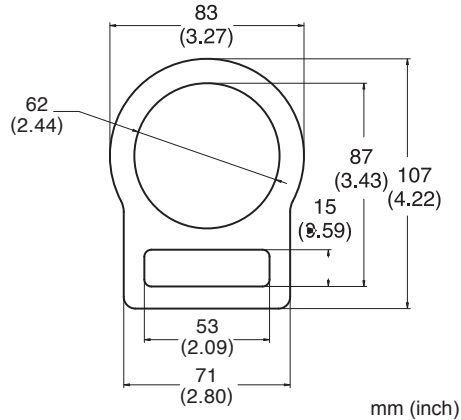

**N-419R
Roller Stamped D-Ring**

Sheet steel, heat treated
 100% proof loaded to 3600 lbs / 16 kN
 Min. Breaking load : 5000 lbs / 23 kN
 Meets :
 ● ANSI Z359.12-2019
 ● CSA Z259.12-16
 Net weight : 5.0 oz. / 142 g

Zinc Plated

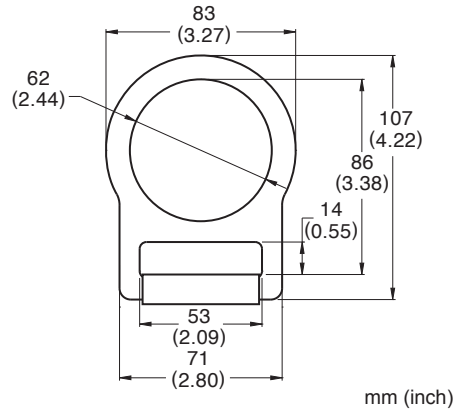
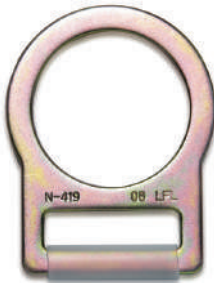

**N-477
Stamped Bent D-Ring**

Sheet steel, heat treated
 100% proof loaded to 3600 lbs / 16 kN
 Min. Breaking load : 5000 lbs / 23 kN
 Meets :
 ● ANSI Z359.12-2019
 ● CSA Z259.12-16
 Net weight : 4.8 oz. / 138 g

Zinc Plated

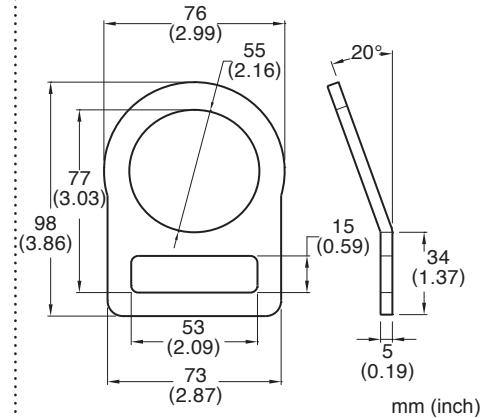
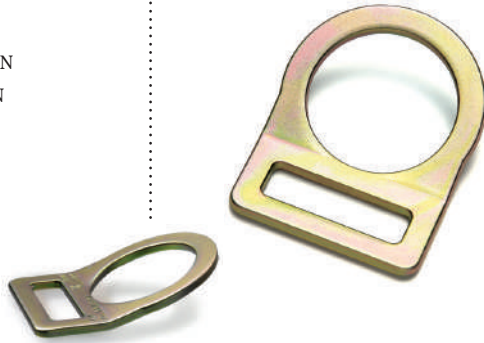

**N-417
D-Ring**

Forged steel, heat treated
 100% proof loaded to 3600 lbs / 16 kN
 Min. Breaking load : 5000 lbs / 23 kN
 Meets :
 ● ANSI Z359.12-2019
 ● CSA Z259.12-16
 Net weight : 8.0 oz. / 227 g

Zinc Plated

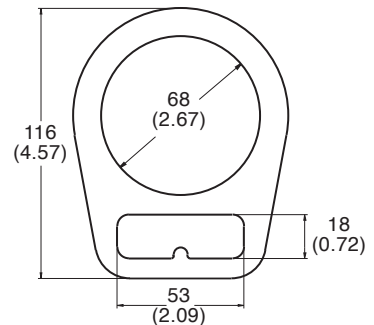

**N-437
Bent D-Ring**

Forged steel, heat treated
 100% proof loaded to 3600 lbs / 16 kN
 Min. Breaking load : 5000 lbs / 23 kN
 Meets :
 ● ANSI Z359.12-2019
 ● CSA Z259.12-16
 Net weight : 7.9 oz. / 225 g

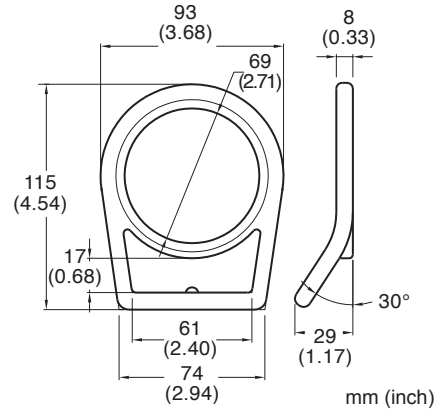

Zinc Plated

**N-476
D-Ring**

Forged steel, heat treated
 100% proof loaded to 3600 lbs / 16 kN
 Min. Breaking load : 5000 lbs / 23 kN
 Meets :
 ● ANSI Z359.12-2019
 ● CSA Z259.12-16
 Net weight : 7.9 oz. / 225 g

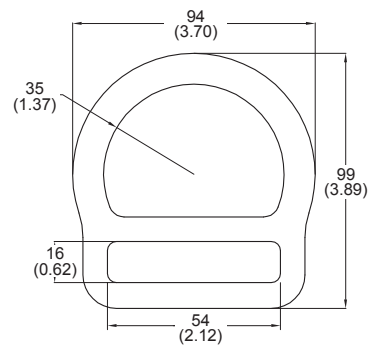

Zinc Plated

**N-476R
Roller D-Ring**

Forged steel, heat treated
 100% proof loaded to 3600 lbs / 16 kN
 Min. Breaking load : 5000 lbs / 23 kN
 Meets :
 ● ANSI Z359.12-2019
 ● CSA Z259.12-16
 Net weight : 8.0 oz. / 227 g

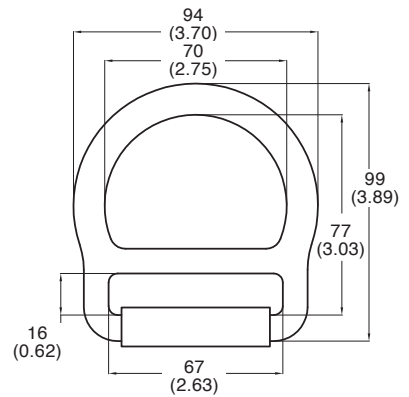

Zinc Plated

**N-455
Stamped D-Ring**

Sheet steel, heat treated
 100% proof loaded to 3600 lbs / 16 kN
 Min. Breaking load : 5000 lbs / 23 kN
 Meets :
 ● ANSI Z359.12-2019
 ● CSA Z259.12-16
 Net weight : 4.2 oz. / 120 g

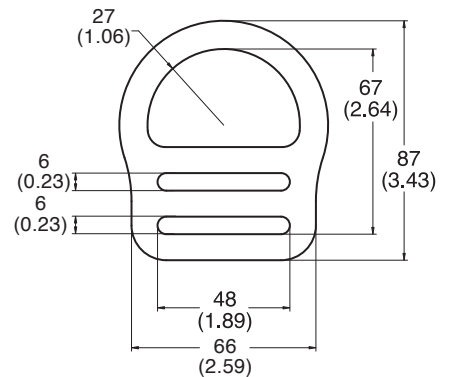

Zinc Plated

**N-4053
3-Bar D-Ring**

Forged steel, heat treated
 100% proof loaded to 3600 lbs / 16 kN
 Min. Breaking load : 5000 lbs / 23 kN
 Meets :
 ● ANSI Z359.12-2019
 ● CSA Z259.12-16
 Net weight : 3.49 oz. / 99 g

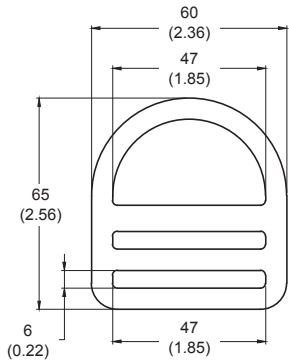

mm (inch)

Zinc Plated

**N-460
D-Ring**

Forged steel, heat treated
 100% proof loaded to 3600 lbs / 16 kN
 Min. Breaking load : 5000 lbs / 23 kN
 Meets :
 ● ANSI Z359.12-2019
 ● CSA Z259.12-16
 Net weight : 6.9 oz. / 180 g

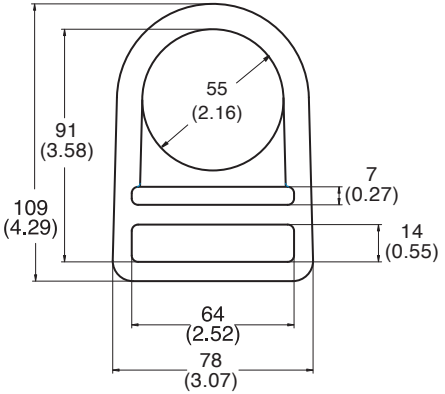

mm (inch)

Zinc Plated

**N-461
D-Ring**

Forged steel, heat treated
 100% proof loaded to 3600 lbs / 16 kN
 Min. Breaking load : 5000 lbs / 23 kN
 Meets :
 ● ANSI Z359.12-2019
 ● CSA Z259.12-16
 Net weight : 5.9 oz. / 170 g

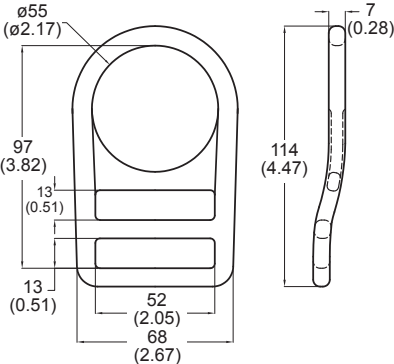

mm (inch)

Zinc Plated

**N-469
D-Ring with Clip**

Forged steel, heat treated
 100% proof loaded to 3600 lbs / 16 kN
 Min. Breaking load : 5000 lbs / 23 kN
 Meets :
 ● ANSI Z359.12-2019
 ● CSA Z259.12-16
 Net weight : 9.4 oz. / 269 g

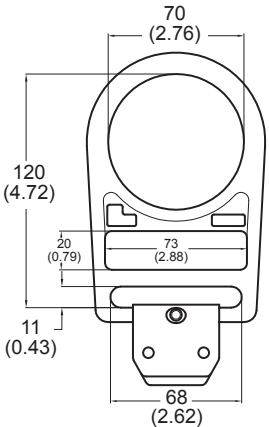

mm (inch)

Zinc Plated

**N-478
Bent D-Ring**

Forged steel, heat treated
 100% proof loaded to 3600 lbs / 16 kN
 Min. Breaking load : 5000 lbs / 23 kN
 Meets :
 ● ANSI Z359.12-2019
 ● CSA Z259.12-16
 Net weight : 3.8 oz. / 108 g

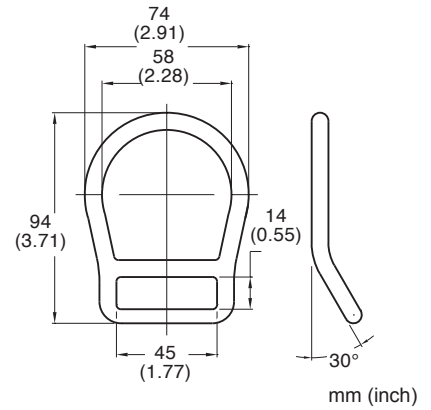
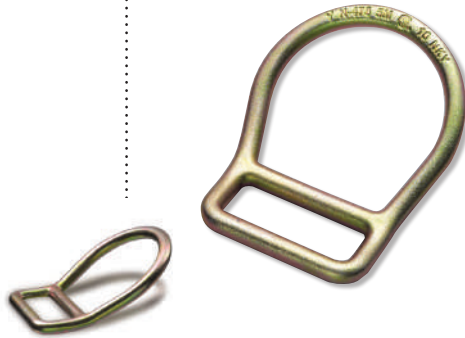

Zinc Plated

**N-493
Stamped D-Ring**

Sheet steel, heat treated
 100% proof loaded to 3600 lbs / 16kN
 Min. Breaking load : 5000 lbs / 23 kN
 Meets :
 ● ANSI Z359.12-2019
 ● CSA Z259.12-16
 Net weight : 2.78oz. / 79g

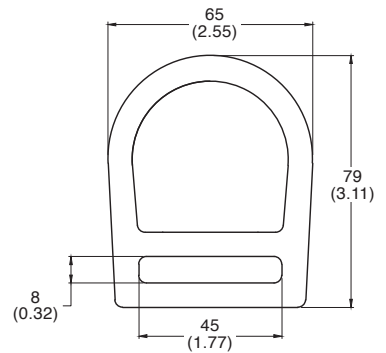

Zinc Plated

**N-493-BT
Stamped Bent D-Ring**

Sheet steel, heat treated
 100% proof loaded to 3600 lbs / 16kN
 Min. Breaking load : 5000 lbs / 23 kN
 Meets :
 ● ANSI Z359.12-2019
 ● CSA Z259.12-16
 Net weight : 2.78oz. / 79g

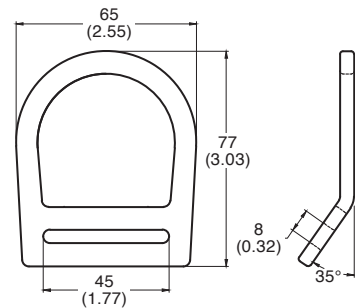

Zinc Plated

**N-492
D-Ring**

Forged steel, heat treated
 100% proof loaded to 3600 lbs / 16kN
 Min. Breaking load : 5000 lbs / 23 kN
 Meets :
 ● ANSI Z359.12-2019
 ● CSA Z259.12-16
 Net weight : 4.48oz. / 127g

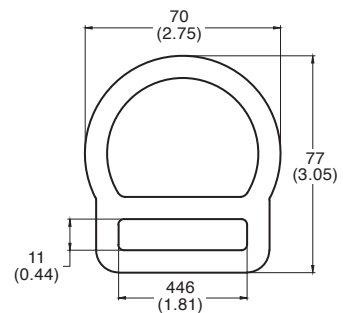

Zinc Plated

mm (inch)

**N-492-BT
Bent D-Ring**

Forged steel, heat treated
 100% proof loaded to 3600 lbs / 16kN
 Min. Breaking load : 5000 lbs / 23 kN
 Meets :
 ● ANSI Z359.12-2019
 ● CSA Z259.12-16
 Net weight : 4.48oz. / 127g

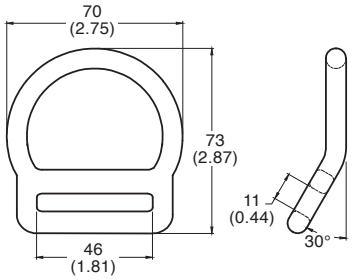

Zinc Plated

mm (inch)

**N-403XL
Stamped D-Ring**

Sheet steel, heat treated
 100% proof loaded to 3600 lbs / 16 kN
 Min. Breaking load : 5000 lbs / 23 kN
 Meets :
 ● ANSI Z359.12-2019
 ● CSA Z259.12-16
 Net weight : 2.5 oz. / 71 g



Light Weight Design

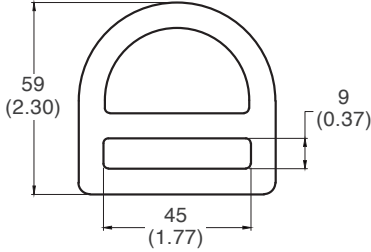

Zinc Plated

mm (inch)

**N-403L
Stamped D-Ring**

Sheet steel, heat treated
 100% proof loaded to 3600 lbs / 16 kN
 Min. breaking load : 5000 lbs / 23 kN
 Meets :
 ● ANSI Z359.12-2019
 ● CSA Z259.12-16
 Net weight : 2.8 oz. / 78 g

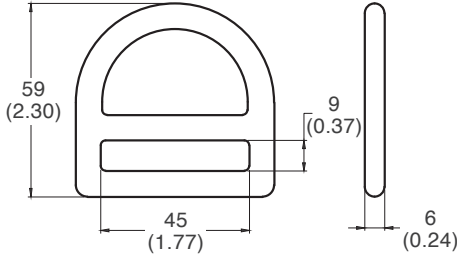

Zinc Plated

mm (inch)

**N-403
D-Ring**

Forged steel, heat treated
 100% proof loaded to 3600 lbs / 16 kN
 Min. Breaking load : 5000 lbs / 23 kN
 Meets :
 ● ANSI Z359.12-2019
 ● CSA Z259.12-16
 Net weight : 2.8 oz. / 80 g

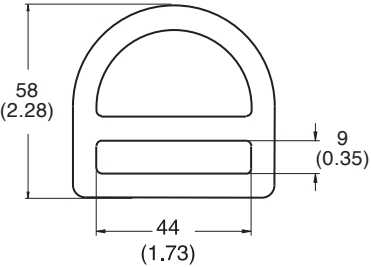

Zinc Plated

mm (inch)

**N-445
Bent D-Ring**

Forged steel, heat treated
 100% proof loaded to 3600 lbs / 16 kN
 Min. Breaking load : 5000 lbs / 23 kN
 Meets :
 ● ANSI Z359.12-2019
 ● CSA Z259.12-16
 Net weight : 3.1 oz. / 90 g

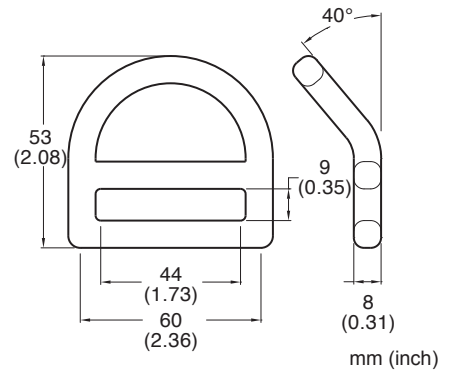

Zinc Plated

**N-445L
Stamped Bent D-Ring**

Sheet steel, heat treated
 100% proof loaded to 3600 lbs / 16 kN
 Min. breaking load : 5000 lbs / 23 kN
 Meets :
 ● ANSI Z359.12-2019
 ● CSA Z259.12-16
 Net weight : 2.8 oz. / 80 g

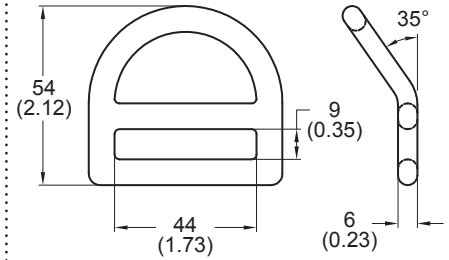
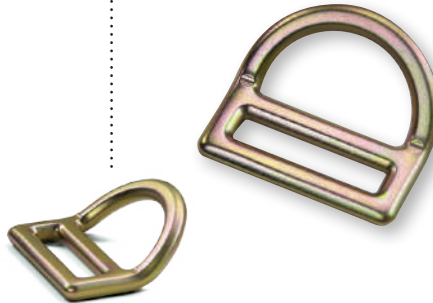

Zinc Plated

mm (inch)

N-430
Stamped D-Ring, with bar

Sheet steel, heat treated
 100% proof loaded to 3600 lbs / 16 kN
 Mini. Breaking load : 5000 lbs / 23 kN
 Meets :
 ● ANSI Z359.12-2019
 ● CSA Z259.12-16
 Net weight : 3.1 oz. / 90 g

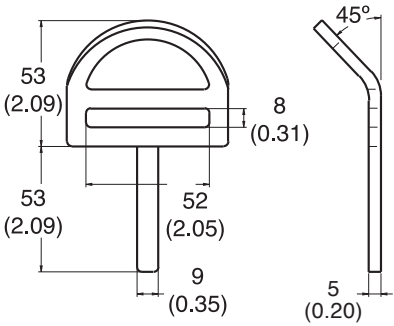

mm (inch)

Zinc Plated

N-432
Stamped D-Ring

Sheet steel, heat treated
 100% proof loaded to 3600 lbs / 16 kN
 Mini. Breaking load : 5000 lbs / 23 kN
 Meets :
 ● ANSI Z359.12-2019
 ● CSA Z259.12-16
 Net weight : 2.8 oz. / 80 g

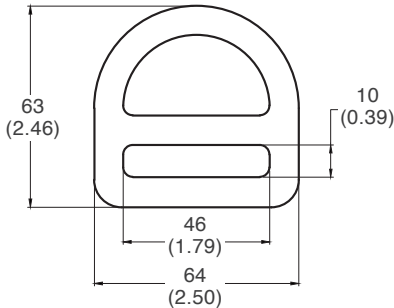

mm (inch)

Zinc Plated

N-431
Stamped Bent D-Ring

Sheet steel, heat treated
 100% proof loaded to 3600 lbs / 16 kN
 Mini. Breaking load : 5000 lbs / 23 kN
 Meets :
 ● ANSI Z359.12-2019
 ● CSA Z259.12-16
 Net weight : 2.8 oz. / 80 g

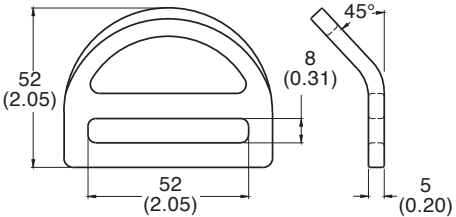

mm (inch)

Zinc Plated

N-4052
Stamped Bent D-Ring

Sheet steel, heat treated
 100% proof loaded to 3600 lbs / 16 kN
 Min. Breaking load : 5000 lbs / 23 kN
 Meets :
 ● ANSI Z359.12-2019
 ● CSA Z259.12-16
 Net weight : 4.97 oz. / 141 g

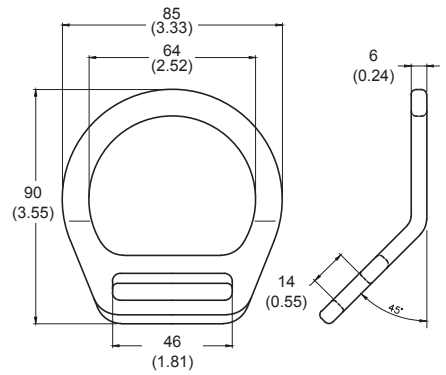

mm (inch)

Zinc Plated

N-407L
Stamped D-Ring

Sheet steel, heat treated
 100% proof loaded to 3600 lbs / 16 kN
 Mini. Breaking load : 5000 lbs / 23 kN
 Meets :
 ● ANSI Z359.12-2019
 ● CSA Z259.12-16
 Net weight : 2.8 oz. / 78 g

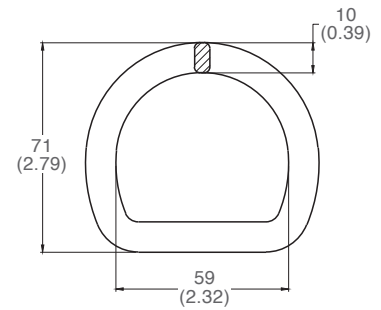

mm (inch)

Zinc Plated

N-4021L
Stamped D-Ring

Sheet steel, heat treated
 100% proof loaded to 3600 lbs / 16 kN
 Mini. Breaking load : 5000 lbs / 23 kN
 Meets :
 ● ANSI Z359.12-2019
 ● CSA Z259.12-16
 Net weight : 2.8 oz. / 80 g

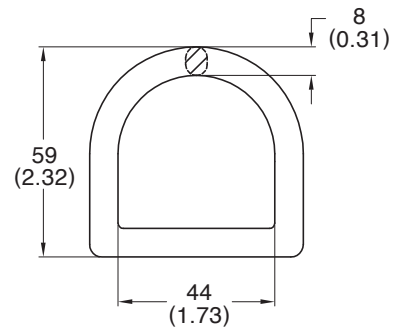

mm (inch)

Zinc Plated

**N-407
D-Ring**

Forged steel, heat treated
100% proof loaded to 3600 lbs / 16 kN
Min. Breaking load : 5000 lbs / 23 kN
Meets :
● ANSI Z359.12-2019
● CSA Z259.12-16
Net weight : 4.4 oz. / 126 g

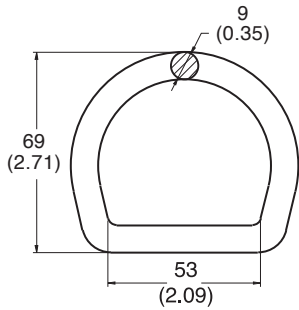

Zinc Plated

mm (inch)

**N-407R
Roller D-Ring**

Forged steel, heat treated
100% proof loaded to 3600 lbs / 16 kN
Min. Breaking load : 5000 lbs / 23 kN
Meets :
● ANSI Z359.12-2019
● CSA Z259.12-16
Net weight : 4.5 oz. / 129 g

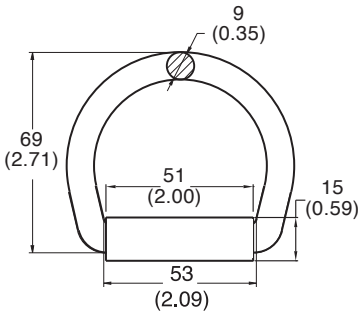

Zinc Plated

mm (inch)

**N-408
D-Ring**

Forged steel, heat treated
100% proof loaded to 3600 lbs / 16 kN
Min. Breaking load : 5000 lbs / 23 kN
Meets :
● ANSI Z359.12-2019
● CSA Z259.12-16
Net weight : 5.3 oz. / 150 g

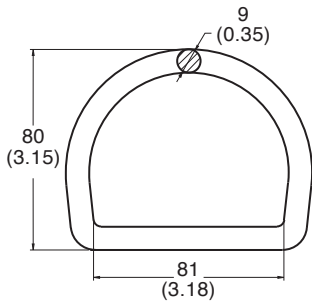

Zinc Plated

mm (inch)

**N-408R
Roller D-Ring**

Forged steel, heat treated
100% proof loaded to 3600 lbs / 16 kN
Min. Breaking load : 5000 lbs / 23 kN
Meets :
● ANSI Z359.12-2019
● CSA Z259.12-16
Net weight : 5.4 oz. / 153 g

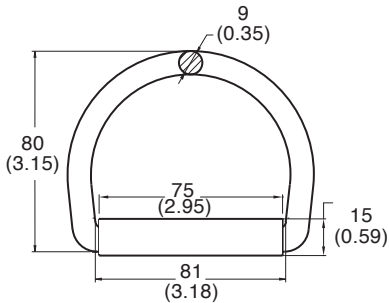

Zinc Plated

mm (inch)

**N-402
D-Ring**

Forged steel, heat treated
 100% proof loaded to 3600 lbs / 16 kN
 Mini. Breaking load : 5000 lbs / 23 kN
 Meets :
 ● ANSI Z359.12-2019
 ● CSA Z259.12-16
 Net weight : 3.0 oz. / 86 g

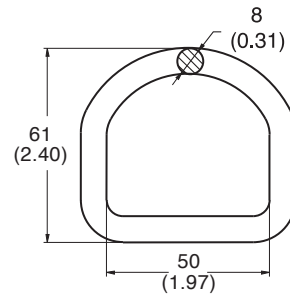

Zinc Plated

mm (inch)

**N-402W
Welded D-Ring**

Steel
 Min. Breaking load : 5000 lbs / 23 kN
 Net weight : 2.33 oz. / 66 g

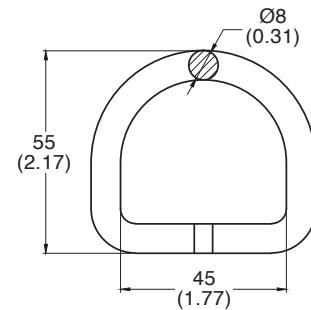

Zinc Plated

mm (inch)

**N-404
Stamped D-Ring**

Sheet steel, heat treated
 100% proof loaded to 3600 lbs / 16 kN
 Min. Breaking load : 5000 lbs / 23 kN
 Meets :
 ● ANSI Z359.12-2019
 ● CSA Z259.12-16
 Net weight : 2.5 oz. / 70 g

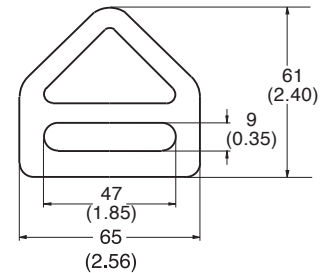

Zinc Plated

mm (inch)

**N-404R
Stamped Roller D-Ring**

Sheet steel, heat treated
 100% proof loaded to 3600 lbs / 16 kN
 Min. Breaking load : 5000 lbs / 23 kN
 Meets :
 ● ANSI Z359.12-2019
 ● CSA Z259.12-16
 Net weight : 2.8 oz. / 77 g

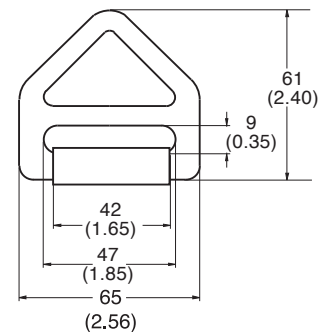
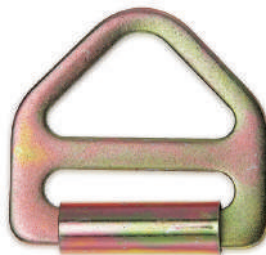

Zinc Plated

mm (inch)

**N-429
Delta D-Ring**

Forged steel, heat treated
 100% proof loaded to 3600 lbs / 16 kN
 Min. Breaking load : 5000 lbs / 23 kN
 Meets :
 ● ANSI Z359.12-2019
 ● CSA Z259.12-16
 Net weight : 1.6 oz. / 45 g

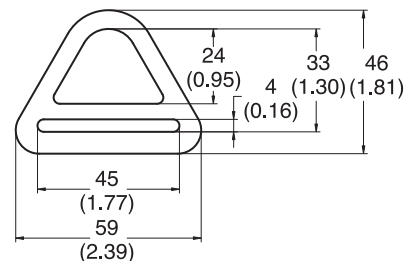

Zinc Plated

mm (inch)

**N-475
D-Ring**

Forged steel, heat treated
 100% proof loaded to 3600 lbs / 16 kN
 Min. Breaking load : 5000 lbs / 23 kN
 Meets :
 ● ANSI Z359.12-2019
 ● CSA Z259.12-16
 Net weight : 4.2 oz. / 120 g

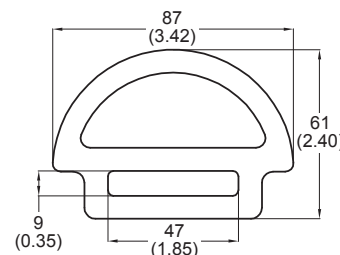

Zinc Plated

mm (inch)

**N-449
D-Ring**

Forged steel, heat treated
 100% proof loaded to 3600 lbs / 16 kN
 Min. Breaking load : 5000 lbs / 23 kN
 Meets :
 ● ANSI Z359.12-2019
 ● CSA Z259.12-16
 Net weight : 2.1 oz. / 60 g

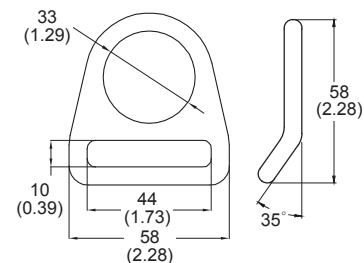

Zinc Plated

mm (inch)

**N-406
D-Ring**

Forged steel, heat treated
 100% proof loaded to 3600 lbs / 16 kN
 Min. Breaking load : 5000 lbs / 23 kN
 Meets :
 ● ANSI Z359.12-2019
 ● CSA Z259.12-16
 Net weight : 4.0 oz. / 120 g

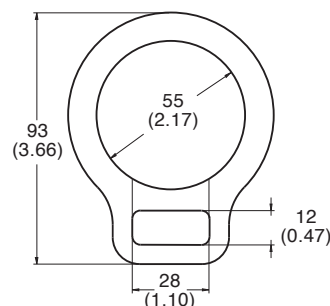

Zinc Plated

mm (inch)

**N-487
Stamped O Ring**

Sheet steel, heat treated
 100% proof loaded to 3600 lbs / 16kN
 Min. Breaking load : 5000 lbs / 23 kN
 Meets :
 ● ANSI Z359.12-2019
 ● CSA Z259.12-16
 Net weight : 2.0 oz. / 57 g

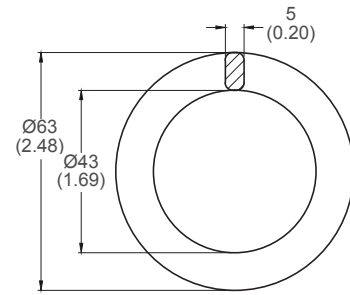

Zinc Plated

mm (inch)

**N-486
O Ring**

Forged steel, heat treated
 100% proof loaded to 3600 lbs / 16 kN
 Min. Breaking load : 5000 lbs / 23 kN
 Meets :
 ● ANSI Z359.12-2019
 ● CSA Z259.12-16
 Net weight : 2.1 oz. / 60 g

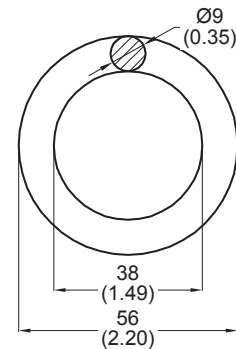

Zinc Plated

mm (inch)

**N-453
O Ring**

Forged steel, heat treated
 100% proof loaded to 3600 lbs / 16 kN
 Min. Breaking load : 5000 lbs / 23 kN
 Meets :
 ● ANSI Z359.12-2019
 ● CSA Z259.12-16
 Net weight : 5.0 oz. / 150 g

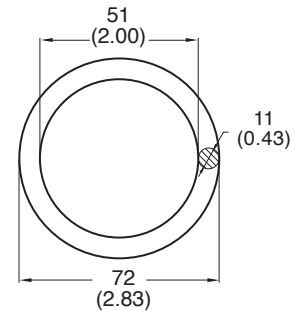

Zinc Plated

mm (inch)

**N-483
O Ring**

Forged steel, heat treated
 100% proof loaded to 3600 lbs / 16 kN
 Min. Breaking load : 5000 lbs / 23 kN
 Meets :
 ● ANSI Z359.12-2019
 ● CSA Z259.12-16
 Net weight : 5.2 oz. / 146 g

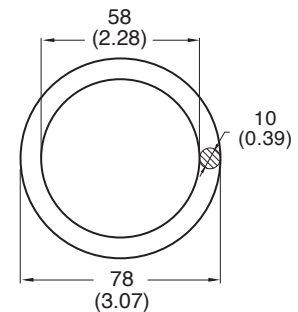

Zinc Plated

mm (inch)

N-489

O Ring

Forged steel, heat treated
 100% proof loaded to 3600 lbs / 16 kN
 Min. Breaking load : 5000 lbs / 23 kN
 Meets :
 ● ANSI Z359.12-2019
 ● CSA Z259.12-16
 Net weight : 7.0 oz. / 198 g

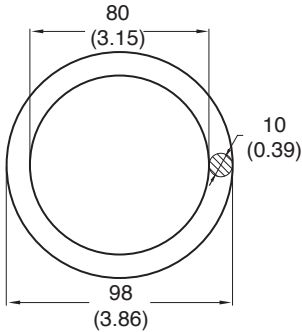

Zinc Plated

mm (inch)

N-422

Quick Buckle

Sheet steel, heat treated
 Min. Breaking load : 4000 lbs / 18 kN
 Meets :
 ● ANSI Z359.12-2019
 ● CSA Z259.12-16
 Net weight : 1.0 oz. / 28 g

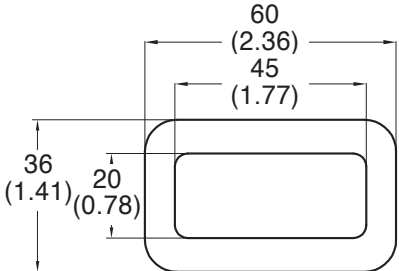

Zinc Plated

mm (inch)

N-4226

Quick Buckle

Sheet steel, heat treated
 Min. Breaking load : 4000 lbs / 18 kN
 Meets :
 ● ANSI Z359.12-2019
 ● CSA Z259.12-16
 Net weight : 1.4 oz. / 39 g

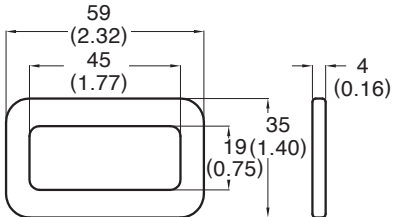

Zinc Plated

mm (inch)

N-4224

Quick Buckle

Sheet steel, heat treated
 Min. Breaking load : 4000 lbs / 18 kN
 Meets :
 ● ANSI Z359.12-2019
 ● CSA Z259.12-16
 Net weight : 1.9 oz. / 55.2 g

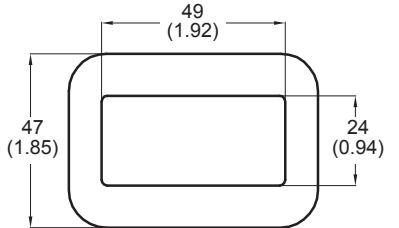
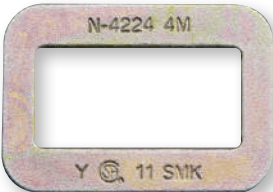

Zinc Plated

mm (inch)

**N-442
Loop Adjuster**

Sheet steel, heat treated
 Min. Breaking load : 4000 lbs / 18 kN
 Meets :
 ● ANSI Z359.12-2019
 ● CSA Z259.12-16
 Net weight : 0.6 oz. / 17 g

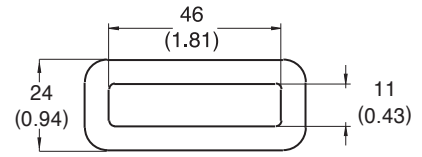

Zinc Plated

mm (inch)

**N-401
Quick Buckle**

Sheet steel, heat treated
 Min. Breaking load : 4000 lbs / 18 kN
 Meets :
 ● ANSI Z359.12-2019
 ● CSA Z259.12-16
 Net weight : 1.9 oz. / 54 g

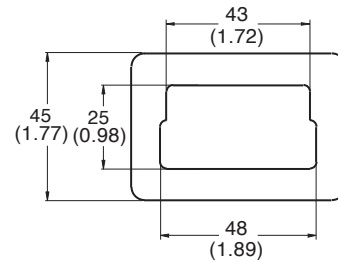

Zinc Plated

*Supplied without sliding pin

mm (inch)

**N-4011
Quick Buckle**

Sheet steel, heat treated
 Min. Breaking load : 4000 lbs / 18 kN
 Meets :
 ● ANSI Z359.12-2019
 ● CSA Z259.12-16
 Net weight : 1.3 oz. / 38 g

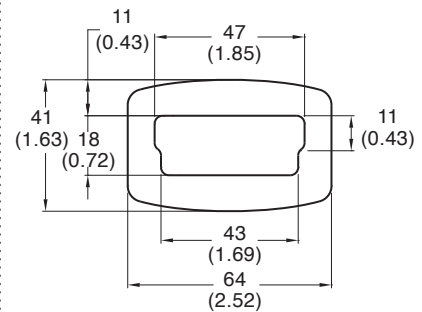
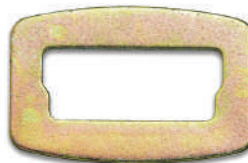

Zinc Plated

mm (inch)

**N-4012
Quick Buckle**

Sheet steel, heat treated
 Min. Breaking load : 4000 lbs / 18 kN
 Meets :
 ● ANSI Z359.12-2019
 ● CSA Z259.12-16
 Net weight : 1.9 oz. / 55 g

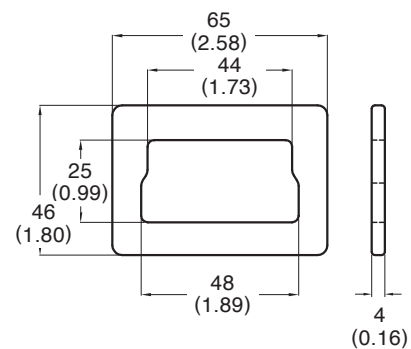

Zinc Plated

mm (inch)

**N-4016
Quick Buckle**

Sheet steel, heat treated
 Min. Breaking load : 4000 lbs / 18 kN
 Meets :
 ● ANSI Z359.12-2019
 ● CSA Z259.12-16
 Net weight : 1.9 oz. / 53 g

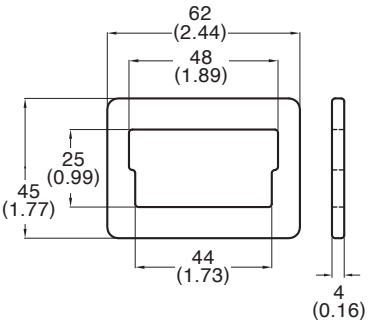
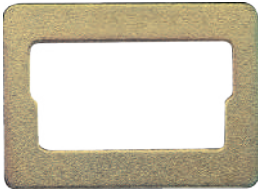

Zinc Plated

mm (inch)

**N-4013
Quick Buckle**

Sheet steel, heat treated
 Min. Breaking load : 4000 lbs / 18 kN
 Meets :
 ● ANSI Z359.12-2019
 ● CSA Z259.12-16
 Net weight : 1.3 oz. / 37 g

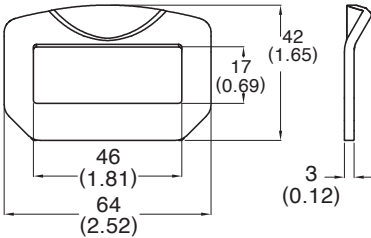

Zinc Plated

mm (inch)

**N-4014
Quick Buckle**

Sheet steel, heat treated
 Min. Breaking load : 4000 lbs / 18 kN
 Meets :
 ● ANSI Z359.12-2019
 ● CSA Z259.12-16
 Net weight : 0.8 oz. / 23 g

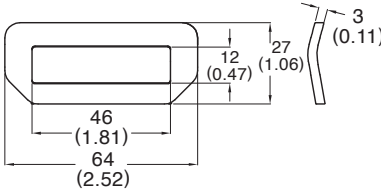

Zinc Plated

mm (inch)

**N-428
Quick Buckle**

Sheet steel, heat treated
 Min. Breaking load : 4000 lbs / 18 kN
 Meets :
 ● ANSI Z359.12-2019
 ● CSA Z259.12-16
 Net weight : 0.5 oz. / 15 g

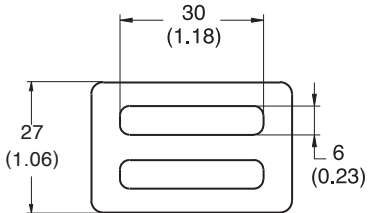

Zinc Plated

mm (inch)

**N-434
Stamped Adjuster**

Sheet steel, heat treated
 Min. Breaking Load : 4000 lbs / 18 kN
 Meets :
 ● ANSI Z359.12-2019
 ● CSA Z259.12-16
 Net weight : 1.4 oz. / 41 g

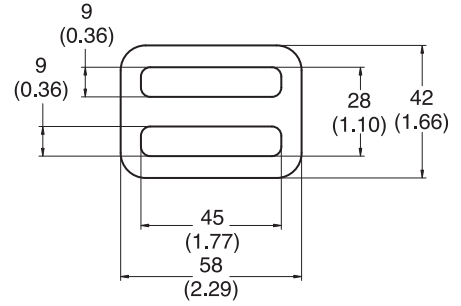

Zinc Plated

mm (inch)

**N-420
Quick Buckle**

Sheet steel, heat treated
 Min. Breaking load : 4000 lbs / 18 kN
 Meets :
 ● ANSI Z359.12-2019
 ● CSA Z259.12-16
 Net weight : 1.0 oz. / 27 g

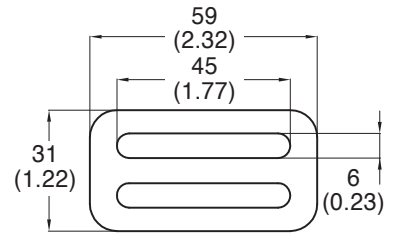

Zinc Plated

mm (inch)

**N-4201
Quick Buckle**

Sheet steel, heat treated
 Min. Breaking load : 4000 lbs / 18 kN
 Meets :
 ● ANSI Z359.12-2019
 ● CSA Z259.12-16
 Net weight : 1.3 oz. / 38 g

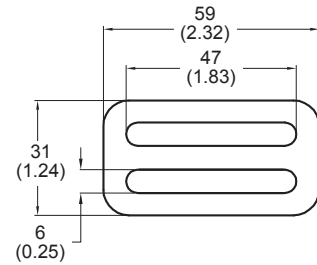

Zinc Plated

mm (inch)

**N-4206
Quick Buckle**

Sheet steel, heat treated
 Min. Breaking load : 4000 lbs / 18 kN
 Meets :
 ● ANSI Z359.12-2019
 ● CSA Z259.12-16
 Net weight : 1.4 oz. / 40 g

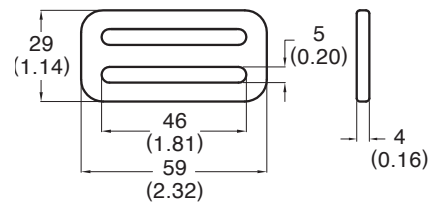

Zinc Plated

mm (inch)

N-435
Slide Buckle - Non-Rated

Sheet steel, heat treated
Min. Tensile strength : 40 lbs / 0.18 kN
Net weight : 0.5 oz. / 13 g

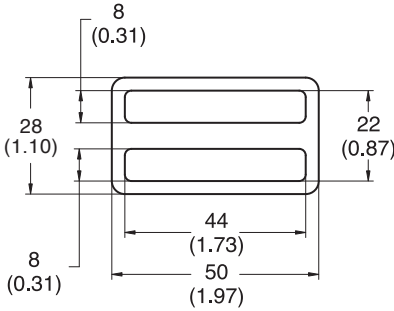

Zinc Plated

mm (inch)

N-421
Quick Buckle

Sheet steel, heat treated
Min. Breaking load : 4000 lbs / 18 kN
Meets :
● ANSI Z359.12-2019
● CSA Z259.12-16
Net weight : 1.3 oz. / 36 g

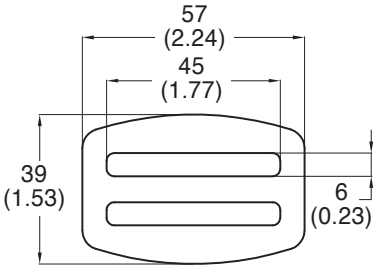

Zinc Plated

mm (inch)

N-4203
Quick Buckle

Sheet steel, heat treated
Min. Breaking load : 4000 lbs / 18 kN
Meets :
● ANSI Z359.12-2019
● CSA Z259.12-16
Net weight : 1.3 oz. / 36 g

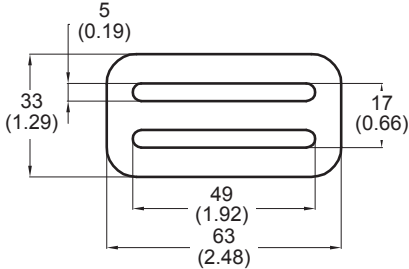
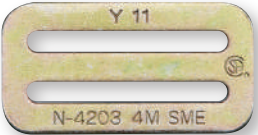

Zinc Plated

mm (inch)

N-4501
Quick Buckle

Sheet steel, heat treated
Min. Breaking load : 4000 lbs / 18 kN
Meets :
● ANSI Z359.12-2019
● CSA Z259.12-16
Net weight : 2.5 oz. / 70 g

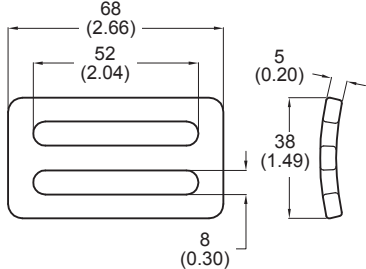

Zinc Plated

mm (inch)

**N-4502
Quick Buckle**

Sheet steel, heat treated
 Min. Breaking load : 4000 lbs / 18 kN
 Meets :
 ● ANSI Z359.12-2019
 ● CSA Z259.12-16
 Net weight : 2.3 oz. / 66 g

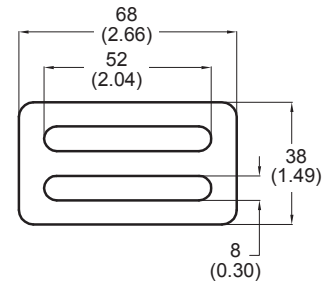

Zinc Plated

mm (inch)

**N-4207
Quick Buckle**

Sheet steel, heat treated
 Min. Breaking load : 4000 lbs / 18 kN
 Meets :
 ● ANSI Z359.12-2019
 ● CSA Z259.12-16
 Net weight : 1.0 oz. / 28 g

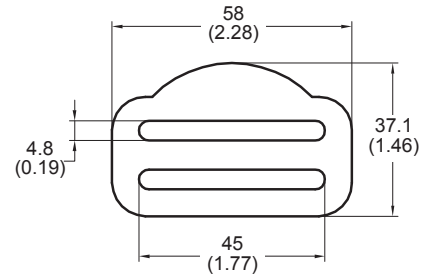

Zinc Plated

mm (inch)

**N-451
Oval Adjuster**

Forged steel, heat treated
 Min. Breaking load : 5000 lbs / 23 kN
 Meets :
 ● ANSI Z359.12-2019
 ● CSA Z259.12-16
 Net weight : 1.9 oz. / 60 g

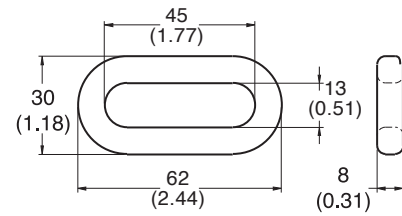

Zinc Plated

mm (inch)

**N-413
Adjuster**

Forged steel, heat treated
 Min. Breaking load : 5000 lbs / 23 kN
 Meets :
 ● ANSI Z359.12-2019
 ● CSA Z259.12-16
 Net weight : 6.1 oz. / 170 g

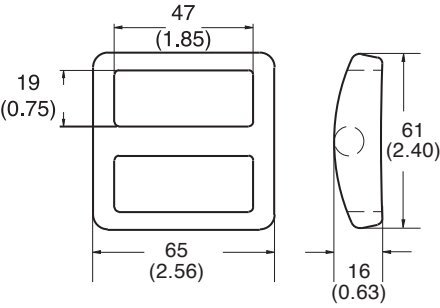

Zinc Plated

mm (inch)

**N-413X
Stamped Adjuster**

Sheet steel, heat treated
 Min. Breaking load : 5000 lbs / 23 kN
 Meets :
 ● ANSI Z359.12-2019
 ● CSA Z259.12-16
 Net weight : 3.5 oz. / 100 g

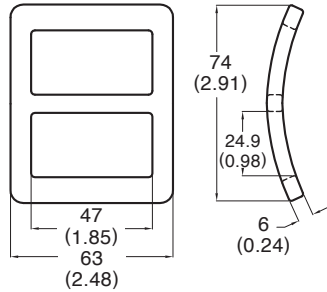

Zinc Plated

mm (inch)

**N-4135
Adjuster**

Forged steel, heat treated
 Min. Breaking load : 5000 lbs / 23 kN
 Meets :
 ● ANSI Z359.12-2019
 ● CSA Z259.12-16
 Net weight : 3.9 oz. / 110 g

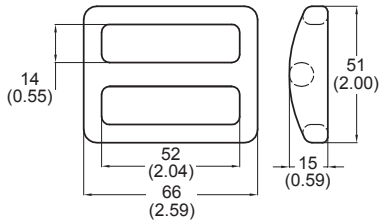
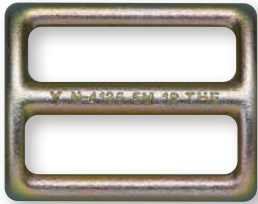

Zinc Plated

mm (inch)

**N-436
Quick Buckle**

Forged steel, heat treated
 Min. Breaking load : 5000 lbs / 23 kN
 Meets :
 ● ANSI Z359.12-2019
 ● CSA Z259.12-16
 Net weight : 2.3 oz. / 65 g

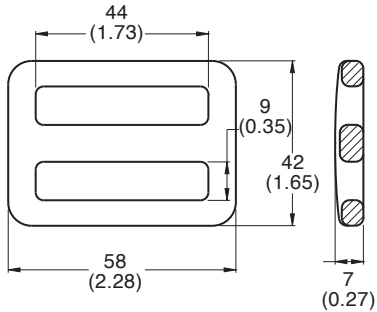

Zinc Plated

mm (inch)

**N-452
Adjuster**

Forged steel, heat treated
 Min. Breaking load : 5000 lbs / 23 kN
 Meets :
 ● ANSI Z359.12-2019
 ● CSA Z259.12-16
 Net weight : 1.6 oz. / 46 g

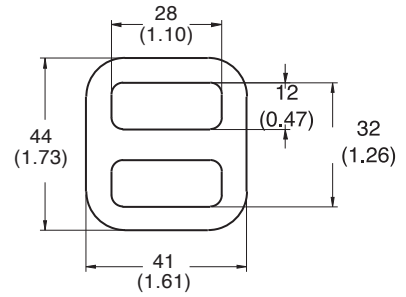

Zinc Plated

mm (inch)

**N-452L
Stamped Adjuster**

Sheet steel, heat treated
 Min. Breaking Load : 5000lbs / 23kN
 Meets :
 ● ANSI Z359.12-2019
 ● CSA Z259.12-16
 Net weight : 1.9 oz. / 53 g

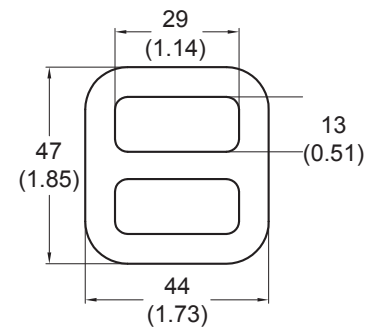

Zinc Plated

mm (inch)

**N-433
Adjuster**

Sheet steel, heat treated
 Min. Breaking load : 4000 lbs / 18 kN
 Meets :
 ● ANSI Z359.12-2019
 ● CSA Z259.12-16
 Net weight : 3.4 oz. / 95 g

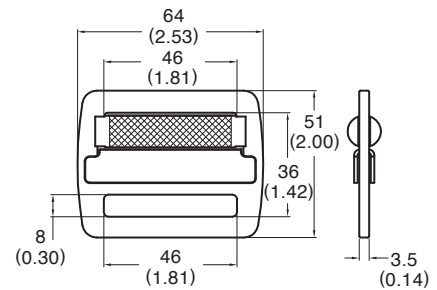

Zinc Plated

mm (inch)

**N-433L
Adjuster**

Sheet steel, heat treated
 Min. Breaking load : 4000 lbs / 18 kN
 Meets :
 ● ANSI Z359.12-2019
 ● CSA Z259.12-16
 Net weight : 3.2 oz. / 90 g

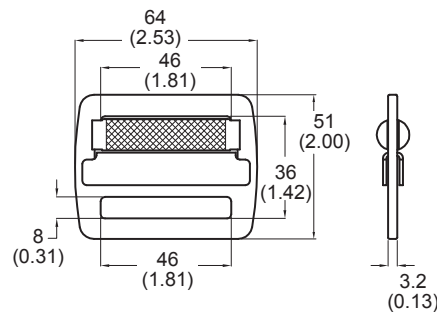

Zinc Plated

mm (inch)

**N-448
Offset Quick Buckle**

Sheet steel, heat treated
 Min. Breaking load : 4000 lbs / 18 kN
 Meets :
 ● ANSI Z359.12-2019
 ● CSA Z259.12-16
 Net weight : 1.8 oz. / 51 g

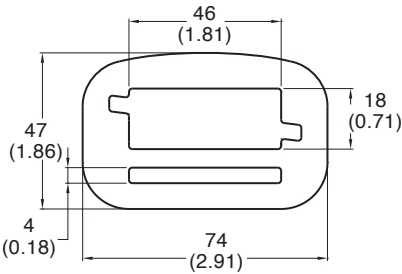

Zinc Plated

mm (inch)

**N-423
Quick Buckle**

Sheet steel, heat treated
 Min. Breaking load : 4000 lbs / 18 kN
 Meets :
 ● ANSI Z359.12-2019
 ● CSA Z259.12-16
 Net weight : 1.8 oz. / 51 g

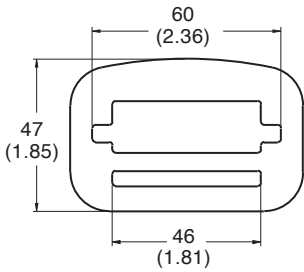
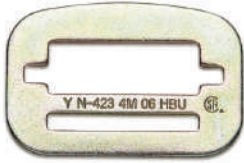

Zinc Plated

mm (inch)

**N-424
Quick Buckle**

Sheet steel, heat treated
 Min. Breaking load : 4000 lbs / 18 kN
 Meets :
 ● ANSI Z359.12-2019
 ● CSA Z259.12-16
 Net weight : 1.2 oz. / 35 g

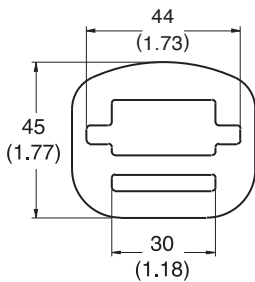
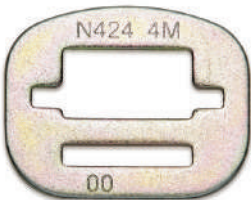

Zinc Plated

mm (inch)

**N-4237
Quick Buckle**

Sheet steel, heat treated
 Min. Breaking load : 4000 lbs / 18 kN
 Meets :
 ● ANSI Z359.12-2019
 ● CSA Z259.12-16
 Net weight : 1.8 oz. / 50 g

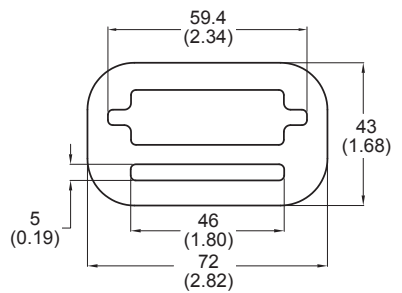

Zinc Plated

mm (inch)

**N-412
Adjuster**

Forged steel, heat treated
 Min. Breaking load : 4000 lbs / 18 kN
 Meets :
 ● ANSI Z359.12-2019
 ● CSA Z259.12-16
 Net weight : 3.1 oz. / 88 g

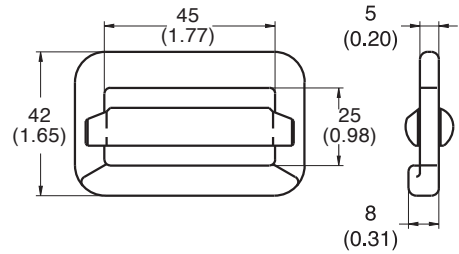
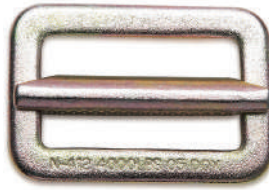

Zinc Plated

mm (inch)

**N-4910
Adjuster Buckle**

Sheet steel, heat treated
 Min. Breaking load : 4000 lbs / 18 kN
 Meets :
 ● ANSI Z359.12-2019
 ● CSA Z259.12-16
 Net weight : 0.9 oz. / 28 g

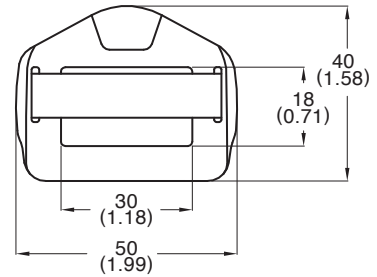

ED Black

mm (inch)

**N-4911
Adjuster Buckle**

Sheet steel, heat treated
 Min. Breaking load : 4000 lbs / 18 kN
 Meets :
 ● ANSI Z359.12-2019
 ● CSA Z259.12-16
 Net weight : 1.5 oz. / 45 g

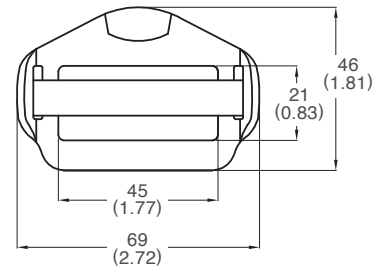

ED Black

mm (inch)

**N-4912
Adjuster Buckle**

Sheet steel, heat treated
 Min. Breaking load : 4000 lbs / 18 kN
 Meets :
 ● ANSI Z359.12-2019
 ● CSA Z259.12-16
 Net weight : 0.83 oz. / 23.5 g

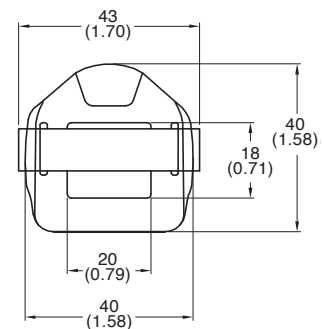

ED Black

mm (inch)

New

**N-443
Adjuster Buckle**

Sheet steel, heat treated
 Min. Breaking load : 4000 lbs / 18 kN
 Meets :
 ● ANSI Z359.12-2019
 ● CSA Z259.12-16
 Net weight : 1.8 oz. / 50 g

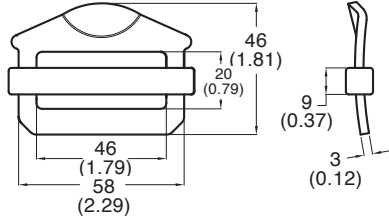
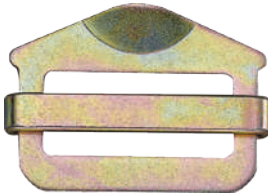

Zinc Plated

mm (inch)

**N-4940-BZP
Quick Buckle**

Sheet steel, heat treated
 Net weight : 0.6 oz. / 16 g

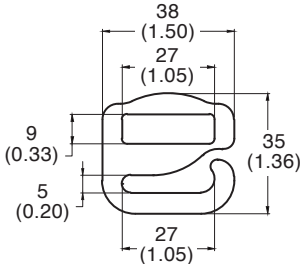

Black Zinc

mm (inch)

**N-4941
Quick Buckle**

Sheet steel, heat treated
 Net weight : 1.0 oz. / 29 g

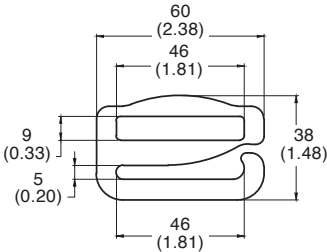

Yellow Zinc

mm (inch)

**N-400
Adjuster**

Sheet steel, heat treated
 Min. Breaking Load : 4000 lbs / 18 kN
 Meets :
 ● ANSI Z359.12-2019
 ● CSA Z259.12-16
 Net weight : 3.3 oz. / 93 g

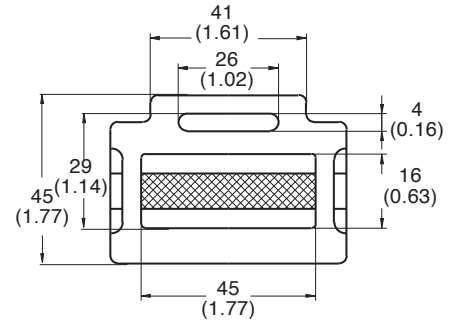
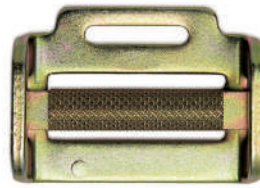

Zinc Plated

mm (inch)

**N-400 / S
Adjuster with spring**

Sheet steel, heat treated
 Min. Breaking Load : 4000 lbs / 18 kN
 Meets :
 ● ANSI Z359.12-2019
 ● CSA Z259.12-16
 Net weight : 3.4 oz. / 96 g

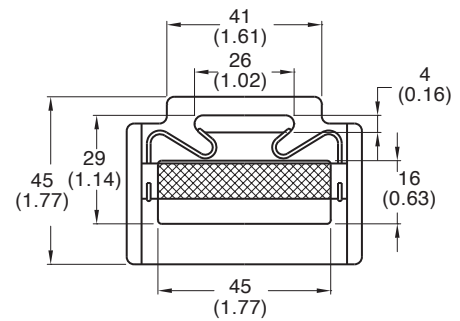
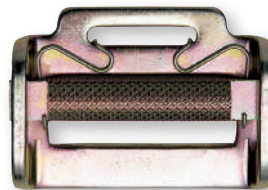

Zinc Plated

mm (inch)

**N-4001
Adjuster**

Sheet steel, heat treated
 Min. Breaking load : 4000 lbs / 18 kN
 Meets :
 ● ANSI Z359.12-2019
 ● CSA Z259.12-16
 Net weight : 2.8 oz. / 80 g

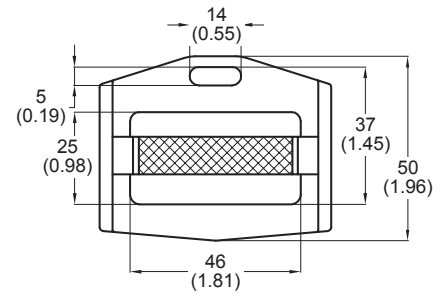
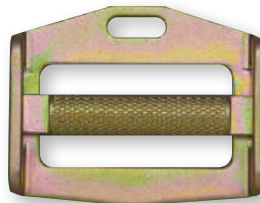

Zinc Plated

mm (inch)

**N-411
Adjuster D-Ring**

Forged steel, heat treated
 100% proof loaded to 3600 lbs / 16 kN
 Min. Breaking load : 5000 lbs / 23 kN
 Meets :
 ● ANSI Z359.12-2019
 ● CSA Z259.12-16
 Net weight : 4.2 oz. / 118 g

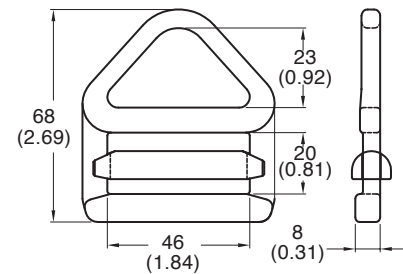

Zinc Plated

mm (inch)

N-4335
Bent Adjuster Buckle
with silding bar adjuster

Sheet steel, heat treated
 Min. Breaking load : 4000 lbs / 18 kN
 Meets :
 ● ANSI Z359.12-2019
 ● CSA Z259.12-16
 Net weight : 2.8 oz. / 78 g

Zinc Plated

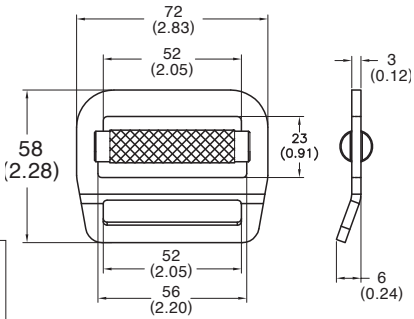
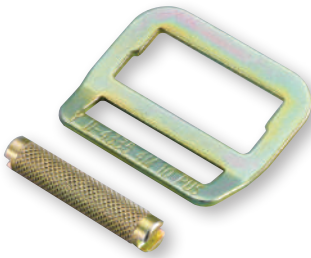

mm (inch)

N-425
Adjuster Buckle
with silding bar adjuster

Sheet steel, heat treated
 Min. Breaking load : 4000 lbs / 18 kN
 Meets :
 ● ANSI Z359.12-2019
 ● CSA Z259.12-16
 Net weight : 2.4 oz. / 67 g

Zinc Plated

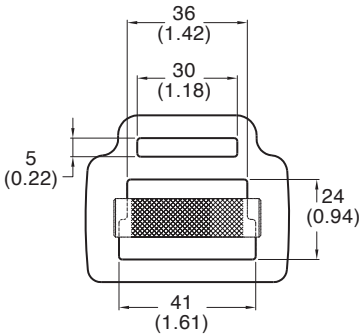
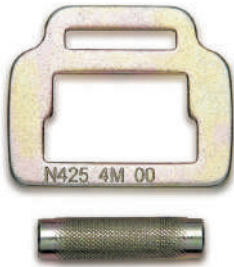

mm (inch)

N-426
Adjuster Buckle
with silding bar adjuster

Sheet steel, heat treated
 Min. Breaking load : 4000 lbs / 18 kN
 Meets :
 ● ANSI Z359.12-2019
 ● CSA Z259.12-16
 Net weight : 3.1 oz. / 88 g

Zinc Plated

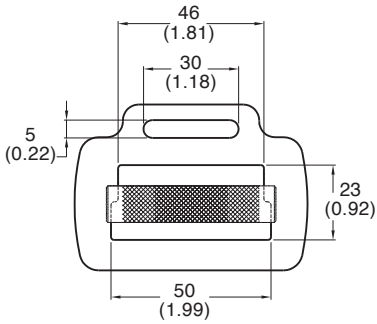
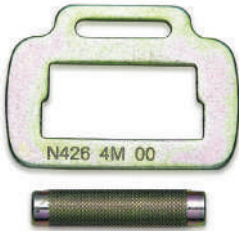

mm (inch)

N-427
Adjuster Buckle
with silding bar adjuster

Sheet steel, heat treated
 Min. Breaking load : 4000 lbs / 18 kN
 Meets :
 ● ANSI Z359.12-2019
 ● CSA Z259.12-16
 Net weight : 3.2 oz. / 90 g

Zinc Plated

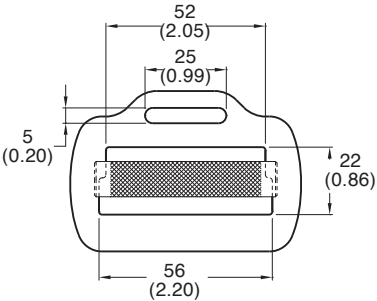

mm (inch)

**N-4797
Extra Lock QR Buckle**

Sheet steel, heat treated
 Min. Breaking Load : 4000 lbs / 18 kN
 Meets :
 ● ANSI Z359.12-2019
 ● CSA Z259.12-16
 Net weight : 5.5 oz. / 156 g
Patent US 9578929

Zinc Plated

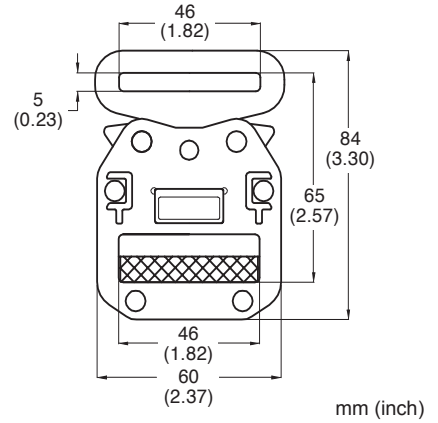

**N-479
QRA Buckle
(Adjust Buckle)**

Sheet steel, heat treated
 Min. Breaking Load : 4000 lbs / 18 kN
 Meets :
 ● ANSI Z359.12-2019
 ● CSA Z259.12-16
 Net weight : 4.3 oz. / 122 g
Patent US 10609989

Zinc Plated

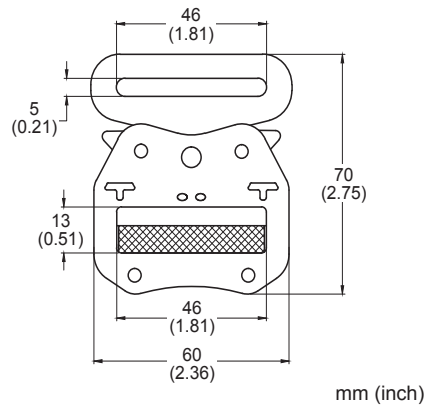
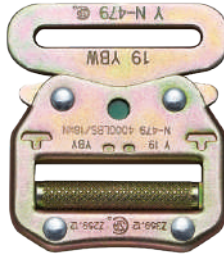

**N-4793
QRA Buckle
(Adjust Buckle)**

Sheet steel, heat treated
 Min. Breaking load : 4000 lbs / 18 kN
 Meets :
 ● ANSI Z359.12-2019
 ● CSA Z259.12-16
 Net weight : 4.5 oz. / 127 g
Patent US 10609989

Zinc Plated

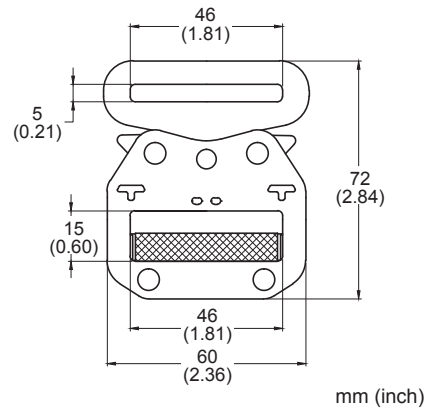

**N-4795
QRA Buckle
(Adjust Buckle)**

Sheet steel, heat treated
 Min. Breaking Load : 4000 lbs / 18 kN
 Meets :
 ● ANSI Z359.12-2019
 ● CSA Z259.12-16
 Net weight : 4.2 oz. / 118 g

ED Black

New

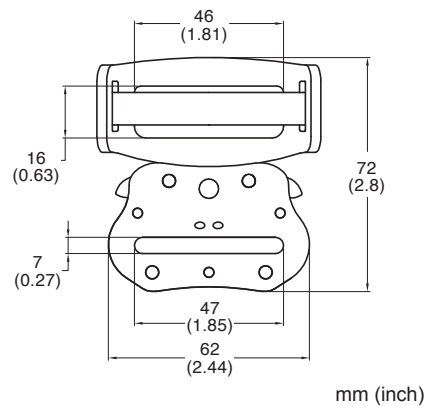

N-439X
Stamped Tongue Buckle, 1-7/8"

Sheet steel, heat treated
 Min. Breaking load : 4000 lbs / 18 kN
 Meets :
 ● ANSI Z359.12-2019
 ● CSA Z259.12-16
 Net weight : 2.7 oz. / 78 g

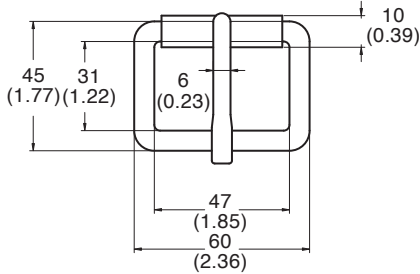
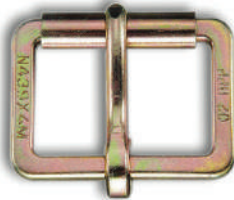

mm (inch)

N-439
Tongue Buckle, 1-7/8"

Forged steel, heat treated
 Min. Breaking load : 4000 lbs / 18 kN
 Meets :
 ● ANSI Z359.12-2019
 ● CSA Z259.12-16
 Net weight : 3.5 oz. / 99 g

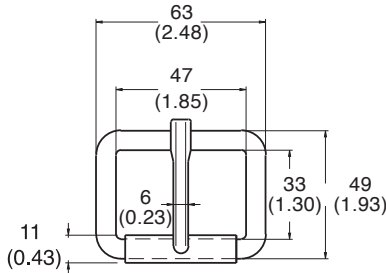

mm (inch)

N-441
Tongue Buckle, 2"

Forged steel, heat treated
 Min. Breaking load : 4000 lbs / 18 kN
 Meets :
 ● ANSI Z359.12-2019
 ● CSA Z259.12-16
 Net weight : 3.3 oz. / 96 g

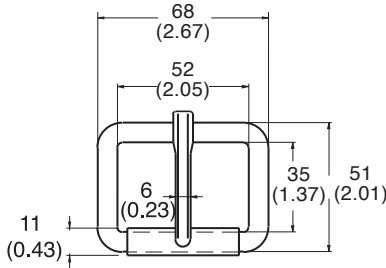

mm (inch)

N-440
Twin Tongue Buckle, 2"

Forged steel, heat treated
 Min. Breaking load : 4000 lbs / 18 kN
 Meets :
 ● ANSI Z359.12-2019
 ● CSA Z259.12-16
 Net weight : 4.0 oz. / 115 g

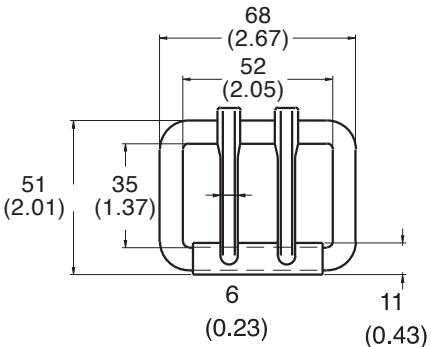
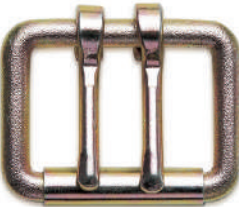

mm (inch)

Zinc Plated



N-DE244-0
Dielectric Carabiner

Alloy steel, heat treated
 Min. Breaking load : 5000 lbs / 23 kN
 Meets:
 ● EN 362 : 2004
 Maximum 4kV Dielectric Resistance
 Net weight : 6.35 oz. / 180 g
Patent US 11364694

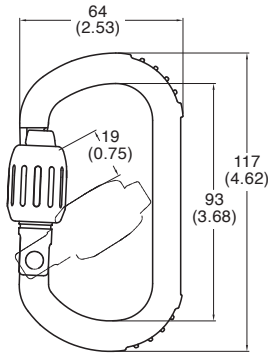

Plastic Over Molded

mm (inch)

N-DE360
Dielectric ANSI Rope Snap Hook

Sheet steel, heat treated
 100% proof loaded to 3600 lbs / 16kN
 Min. Breaking load : 5000 lbs / 23 kN
 Meets :
 ● ANSI Z359.12-2019
 ● CSA Z259.12-16
 ● EN 362 : 2004
 Maximum 9kV Dielectric Resistance
 Net weight : 14.2 oz. / 404 g
Patent US 9885379

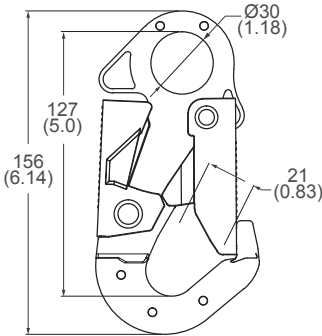

Plastic Over Molded

mm (inch)

N-DE301
Dielectric Rebar Hook

Forged steel, heat treated
 Min. Breaking load : 5000 lbs / 23 kN
 Meets :
 ● EN362 : 2004
 Maximum 9kV Dielectric Resistance
 Net weight : 19.2 oz. / 548g
Patent US 9199105

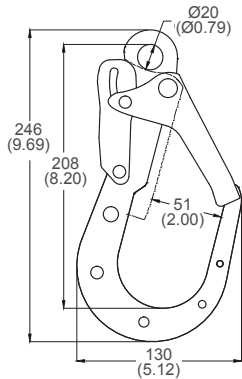

Plastic Over Molded

mm (inch)

N-DE300
Dielectric Snap Hook

Sheet steel, heat treated
 Min. Breaking load : 5000 lbs / 23 kN
 Meets :
 ● EN362 : 2004
 Maximum 9kV Dielectric Resistance
 Net weight : 9.2 oz. / 264 g
Patent US 9199105

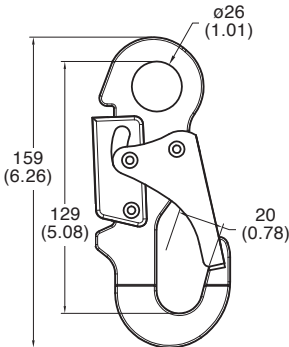

Plastic Over Molded

mm (inch)

**N-DE001
Dielectric D-Ring**

Sheet steel, heat treated
 100% proof loaded to 3600lbs / 16 kN
 Min. Breaking load : 5000 lbs / 23 kN
 Meets :
 ● ANSI Z359.12-2019
 ● CSA Z259.12-16
 Maximum 9kV Dielectric Resistance
 Net weight : 5.8 oz. / 164 g

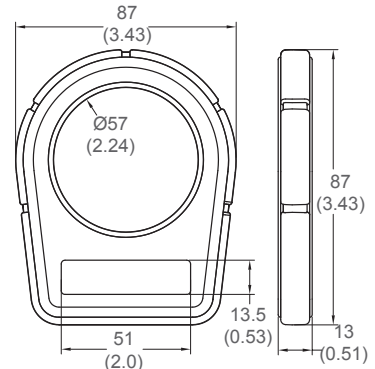

mm (inch)

Plastic Over Molded

**N-DE002
Dielectric Bent D-Ring**

Sheet steel, heat treated
 100% proof loaded to 3600lbs / 16 kN
 Min. Breaking load : 5000 lbs / 23 kN
 Meets :
 ● ANSI Z359.12-2019
 ● CSA Z259.12-16
 Maximum 9kV Dielectric Resistance
 Net weight : 6.1 oz. / 176 g

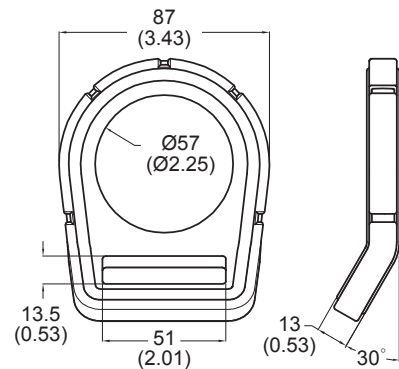

mm (inch)

Plastic Over Molded

**N-DE403
Dielectric D-Ring**

Sheet steel, heat treated
 100% proof loaded to 3600 lbs / 16kN
 Min. Breaking load : 5000 lbs / 23 kN
 Meets :
 ● ANSI Z359.12-2019
 ● CSA Z259.12-16
 Maximum 4kV Dielectric Resistance
 Net weight : 2.7 oz. / 77 g

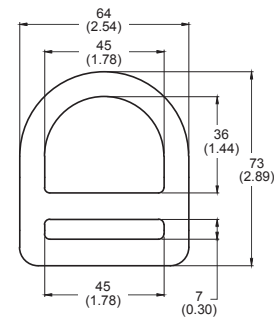

mm (inch)

Plastic Over Molded

**N-DE403B
Dielectric Bent D-Ring**

Sheet steel, heat treated
 100% proof loaded to 3600 lbs / 16kN
 Min. Breaking load : 5000 lbs / 23 kN
 Meets :
 ● ANSI Z359.12-2019
 ● CSA Z259.12-16
 Maximum 4kV Dielectric Resistance
 Net weight : 2.6 oz. / 76 g

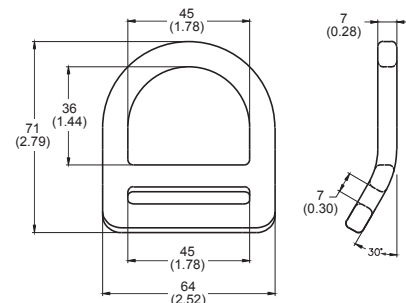

mm (inch)

Plastic Over Molded

**N-DE415
Dielectric D-Ring**

Sheet steel, heat treated
 100% proof loaded to 3600 lbs / 16kN
 Min. Breaking load : 5000 lbs / 23 kN
 Meets :
 ● ANSI Z359.12-2019
 ● CSA Z259.12-16
 Maximum 4kV Dielectric Resistance
 Net weight : 5.3 oz. / 152 g

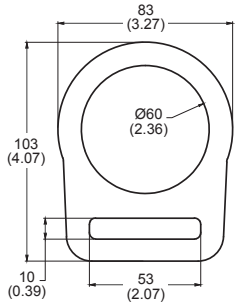

mm (inch)

**N-DE415B
Dielectric Bent D-Ring**

Sheet steel, heat treated
 100% proof loaded to 3600 lbs / 16kN
 Min. Breaking load : 5000 lbs / 23 kN
 Meets :
 ● ANSI Z359.12-2019
 ● CSA Z259.12-16
 Maximum 4kV Dielectric Resistance
 Net weight : 5.2 oz. / 147 g

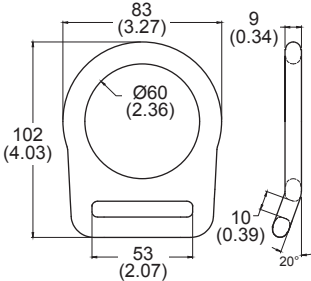

mm (inch)

**N-DE460
Dielectric D-Ring**

Sheet steel, heat treated
 100% proof loaded to 3600 lbs / 16kN
 Min. Breaking load : 5000 lbs / 23 kN
 Meets :
 ● ANSI Z359.12-2019
 ● CSA Z259.12-16
 Maximum 4kV Dielectric Resistance
 Net weight : 7.0 oz. / 200 g

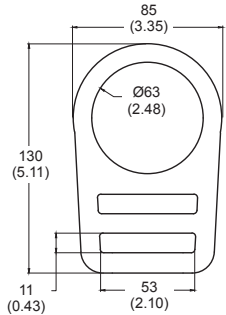

mm (inch)

**N-DE460B
Dielectric Bent D-Ring**

Sheet steel, heat treated
 100% proof loaded to 3600 lbs / 16kN
 Min. Breaking load : 5000 lbs / 23 kN
 Meets :
 ● ANSI Z359.12-2019
 ● CSA Z259.12-16
 Maximum 4kV Dielectric Resistance
 Net weight : 7.0 oz. / 200 g

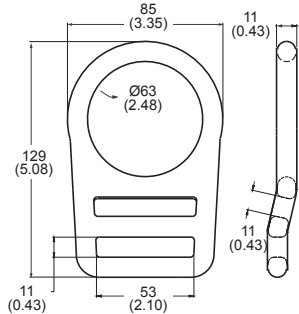

mm (inch)

**N-DE007
Dielectric Quick Release Buckle**

Sheet steel, heat treated

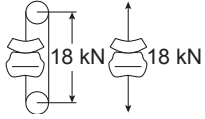

Maximum 9kV Dielectric Resistance

Meets :

- ANSI Z359.12-2019
- CSA Z259.12-16

Net weight : 4.5 oz. / 128 g

Patent US 10010141

Plastic Over Molded

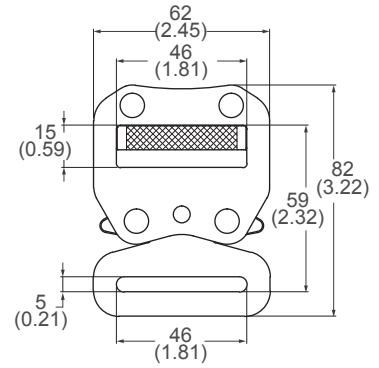

mm (inch)

**N-DE008
Dielectric Quick Release Buckle**

Sheet steel, heat treated

Maximum 9kV Dielectric Resistance

Meets :

- EN 358

Net weight : 5.0 oz. / 141 g

Patent US 10010141

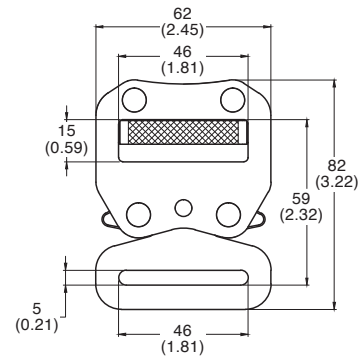

mm (inch)

**N-DE009
Dielectric Adjuster**

Sheet steel, heat treated

Min. Breaking load : 4000 lbs / 18 kN

Meets :

- ANSI Z359.12-2019
- CSA Z259.12-16

Maximum 9kV Dielectric Resistance

Net weight : 2.98 oz. / 85g

Patent Pending

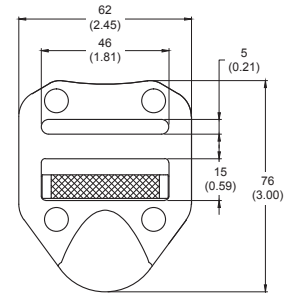

mm (inch)

**N-DE483
Dielectric O-Ring**

Sheet steel, heat treated

100% proof loaded to 3600 lbs / 16kN

Min. Breaking load : 5000 lbs / 23 kN

Meets :

- ANSI Z359.12-2019
- CSA Z259.12-16

Maximum 4kV Dielectric Resistance

Net weight : 3.6 oz. / 103 g

Plastic Over Molded

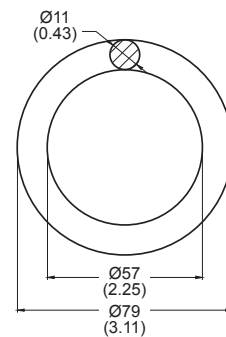

mm (inch)

N-DE518
Dielectric Alum D Ring

Aluminum alloy
 Min. Breaking load : 5000 lbs / 23 kN
 Meets:
 ● ANSI Z359.12-2019
 ● CSA Z259.12-16
 Maximum 4kV Dielectric Resistance
 Net weight : 2.9 oz. / 84 g

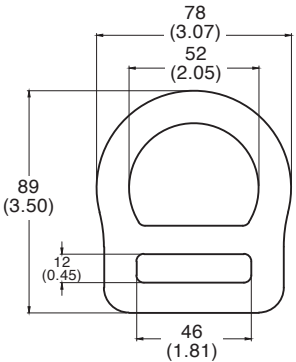

Plastic Over Molded

mm (inch)

N-DE529
Dielectric Bent Alum D Ring

Aluminum alloy
 Min. Breaking load : 5000 lbs / 23 kN
 Meets:
 ● ANSI Z359.12-2019
 ● CSA Z259.12-16
 Maximum 4kV Dielectric Resistance
 Net weight : 4.2 oz. / 120 g

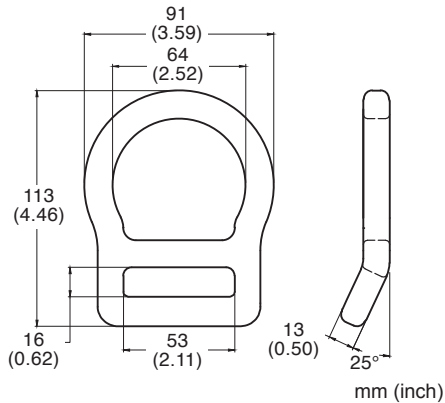

Plastic Over Molded

mm (inch)

N-DE005
Dielectric Quick Buckle

Sheet steel, heat treated
 Min. Breaking load : 4000 lbs / 18 kN
 Meets :
 ● ANSI Z359.12-2019
 ● CSA Z259.12-16
 Maximum 9kV Dielectric Resistance
 Net weight : 1.6 oz. / 45 g

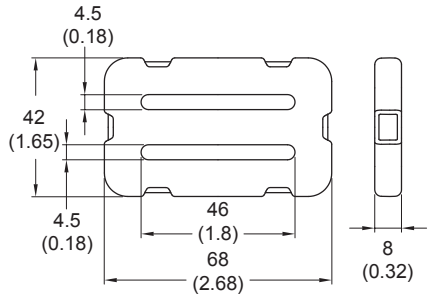

Plastic Over Molded

mm (inch)

N-DE006
Dielectric Quick Buckle

Sheet steel, heat treated
 Min. Breaking load : 4000 lbs / 18 kN
 Meets :
 ● ANSI Z359.12-2019
 ● CSA Z259.12-16
 Maximum 9kV Dielectric Resistance
 Net weight : 2.2 oz. / 61 g

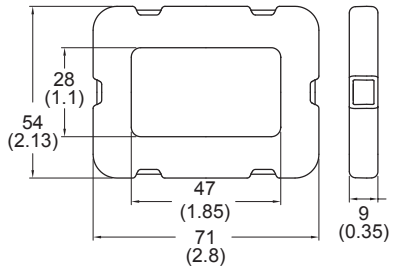

Plastic Over Molded

mm (inch)

N-DE420
Dielectric Quick Buckle

Sheet steel, heat treated
 Min. Breaking load : 4000 lbs / 18 kN
 Meets :
 ● ANSI Z359.12-2019
 ● CSA Z259.12-16
 Maximum 4kV Dielectric Resistance
 Net weight : 1.3 oz. / 36 g

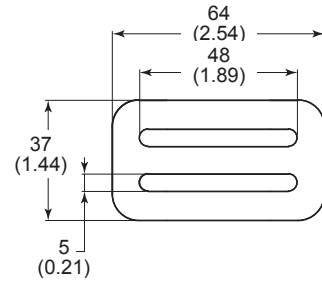

Plastic Over Molded

mm (inch)

N-DE422
Dielectric Quick Buckle

Sheet steel, heat treated
 Min. Breaking load : 4000 lbs / 18 kN
 Meets :
 ● ANSI Z359.12-2019
 ● CSA Z259.12-16
 Maximum 4kV Dielectric Resistance
 Net weight : 1.1 oz. / 32 g

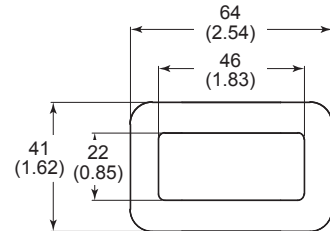

Plastic Over Molded

mm (inch)

N-DE448
Dielectric Quick Buckle

Sheet steel, heat treated
 Min. Breaking load : 4000 lbs / 18 kN
 Meets :
 ● ANSI Z359.12-2019
 ● CSA Z259.12-16
 Maximum 4kV Dielectric Resistance
 Net weight : 2.5 oz. / 70 g

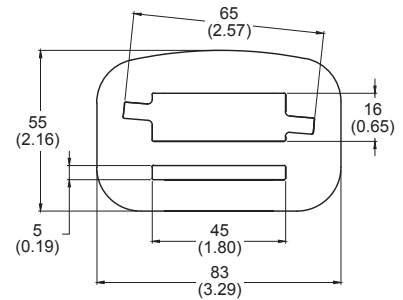

Plastic Over Molded

mm (inch)

N-DE4207
Dielectric Quick Buckle

Sheet steel, heat treated
 Min. Breaking load : 4000 lbs / 18 kN
 Meets :
 ● ANSI Z359.12-2019
 ● CSA Z259.12-16
 Maximum 4kV Dielectric Resistance
 Net weight : 1.3 oz. / 38 g

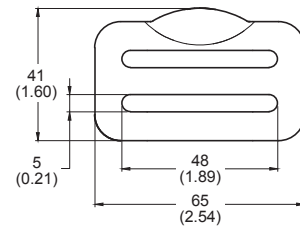

Plastic Over Molded

mm (inch)

N-DE452
Dielectric Quick Buckle

Sheet steel, heat treated
Min. Breaking load: 4000 lbs / 18 kN
Meets :
● ANSI Z359.12-2019
● CSA Z259.12-16
Maximum 4kV Dielectric Resistance
Net weight : 1.3 oz. / 35.7g

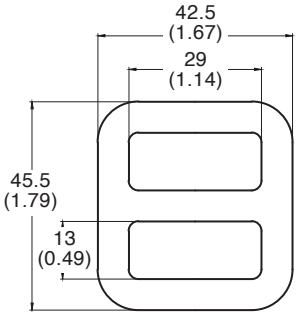

Plastic Over Molded

mm (inch)



N-5271T
Aluminum Rebar Hook
3600 LBS gate/Transverse Load

Forged aluminum alloy
 100% proof loaded to 3600 lbs / 16kN
 Min. Breaking load : 5000 lbs / 23 kN
 Meets:
 ● ANSI Z359.12-2019
 ● CSA Z259.12-16
 ● EN 362 : 2004
 Net weight : 22.3 oz. / 637 g

Anodized

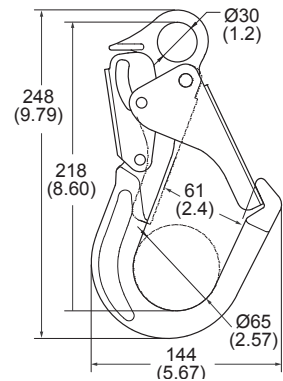

mm (inch)

N-5275T
Indicator Swivel Alum Rebar Hook
3600 LBS gate / Transverse Load

Forged aluminum alloy
 100% proof loaded to 3600 lbs / 16 kN
 Min. Breaking load : 5000 lbs / 23 kN
 Meets :
 ● ANSI Z359.12-2019
 ● CSA Z259.12-16
 ● EN 362 : 2004
 Net weigh : 24.68oz. / 705 g

Anodized

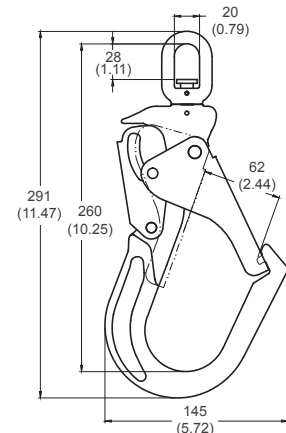

mm (inch)

N-5268
Aluminum Step Bolt Hook
3600 LBS gate strength

Specifically designed for step bolts 16 mm diameter
 Forged aluminum alloy
 100% proof loaded to 3600 lbs / 16 kN
 Min. Breaking load : 5000 lbs / 23 kN
 Meets :
 ● ANSI Z359.12-2019
 ● CSA Z259.12-16
 ● EN 362 : 2004
 Net weight : 14.5 oz. / 414 g

Anodized

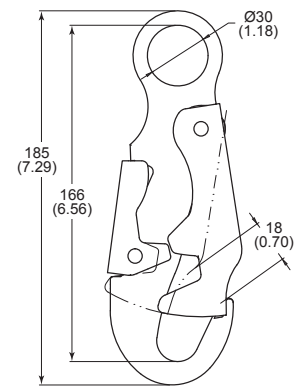

mm (inch)

N-5261
Aluminum Snap Hook
3600 LBS gate strength

Forged aluminum alloy
 100% proof loaded to 3600 lbs / 16 kN
 Min. Breaking load : 5000 lbs / 23 kN
 Meets :
 ● ANSI Z359.12-2019
 ● CSA Z259.12-16
 ● EN 362 : 2004
 Net weight : 8.7 oz. / 247 g

Anodized

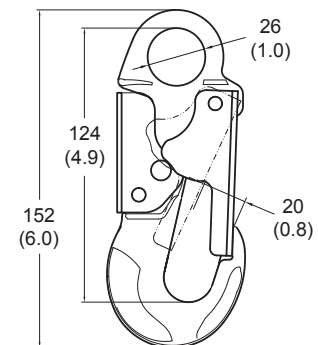

mm (inch)

N-5265
Alum Indicator Swivel Snap Hook
3600 LBS gate strength

Forged aluminum alloy
 100% proof loaded to 3600 lbs / 16 kN
 Min. Breaking load : 5000 lbs / 23 kN
 Meets :
 ● ANSI Z359.12-2019
 ● CSA Z259.12-16
 ● EN 362 : 2004
 Net weight : 10.6 oz. / 304 g
Anodized



Indicator activation

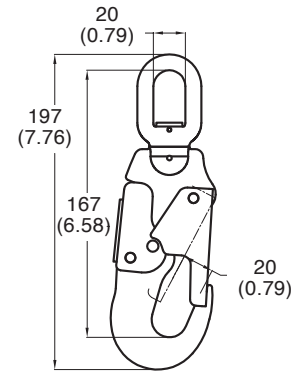

mm (inch)

N-5265 / 0
Aluminum Swivel Snap Hook
3600 LBS gate strength
(non - Indicator)

Forged aluminum alloy
 100% proof loaded to 3600 lbs / 16 kN
 Min. Breaking load : 5000 lbs / 23 kN
 Meets :
 ● ANSI Z359.12-2019
 ● CSA Z259.12-16
 ● EN 362 : 2004
 Net weight : 10.5 oz. / 300 g
Anodized

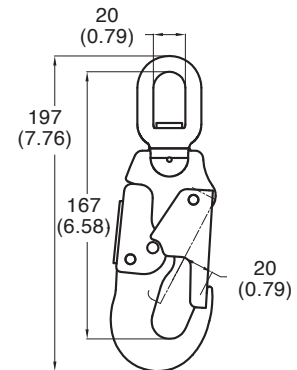

mm (inch)

N-5246
Aluminum Snap Hook

Sheet aluminum alloy
 Min. Breaking load : 5000 lbs / 23 kN
 Meets :
 ● EN 362 : 2004
 Net weight : 6.0 oz. / 169 g
Anodized

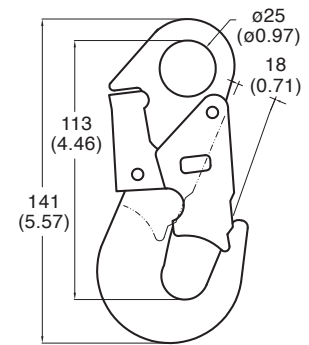

mm (inch)

N-5248
Aluminum Snap Hook

Sheet aluminum alloy
 Min. Breaking load : 5000 lbs / 23 kN
 Meets :
 ● EN 362 : 2004
 Net weight : 8.5 oz. / 244 g
Anodized

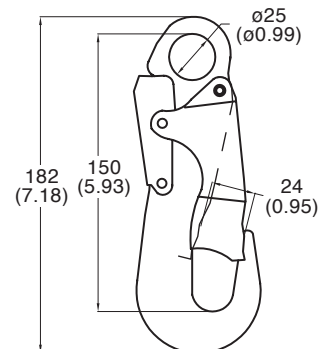

mm (inch)

Aluminum Components



N-331 SRD Attachment Bracket

Forged steel / aluminum alloy
Net weight : 5.6 oz. / 159 g

Patent US 10065057

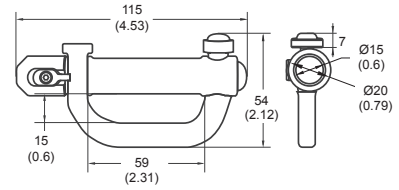

Zinc Plated / Anodized

mm (inch)

N-339 SRD Attachment Bracket

Forged steel
Net weight : 5.43 oz. / 154 g

Patent Pending

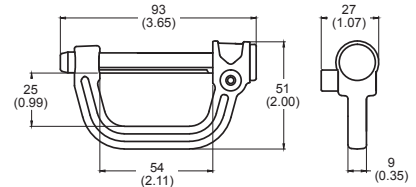
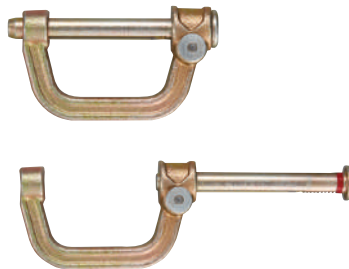

Zinc Plated

mm (inch)

N-502 Aluminum Snap Hook

Forged aluminum alloy
Min. Breaking load : 5000 lbs / 23 kN
Meets :
● EN 362 : 2004
Net weight : 6.7 oz. / 189 g

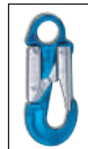

N-502-1
Blue



N-502-2
Green

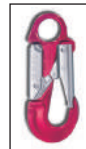

N-502-3
Red

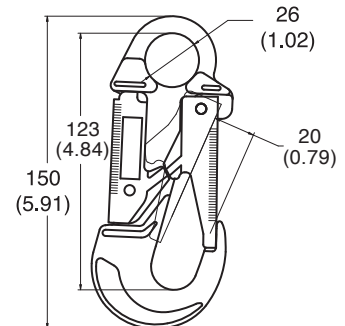

Anodized

mm (inch)

N-504 Aluminum Snap Hook

Forged aluminum alloy
Min. Breaking load : 5000 lbs / 23 kN
Meets :
● EN 362 : 2004
Net weight : 5.5 oz. / 158 g

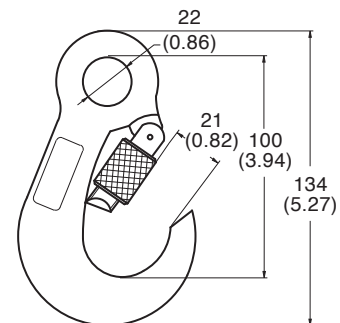

Anodized

mm (inch)

**N-500
Aluminum Rebar Hook**

Forged aluminum alloy
 Min. Breaking load : 5000 lbs / 23 kN
 Meets :
 ● EN 362 : 2004
 Net weight : 18 oz. / 520 g

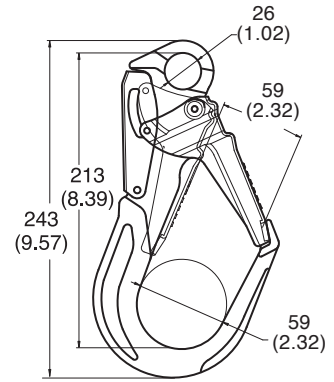

mm (inch)

Anodized

**N-501
Aluminum Rebar Hook**

Forged aluminum alloy
 Min. Breaking load : 5000 lbs / 23 kN
 Meets :
 ● EN 362 : 2004
 Net weight : 16.2 oz. / 460 g

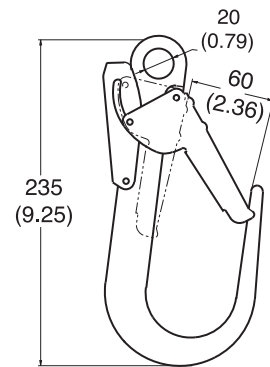

mm (inch)

Anodized

**N-50130
Aluminum Rebar Hook**

Forged aluminum alloy
 Min. Breaking load : 5000 lbs / 23 kN
 Meets :
 ● EN 362 : 2004
 Net weight : 16.8 oz. / 480 g

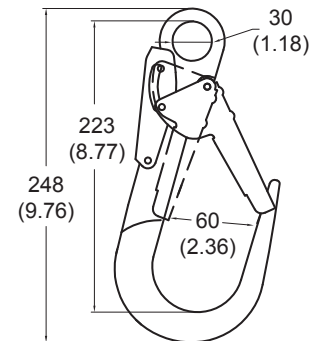

mm (inch)

Anodized

**N-50110
Aluminum Huge Rebar Hook**

Forged aluminum alloy
 Min. Breaking load : 5000 lbs / 23 kN
 Meets :
 ● EN 362 : 2004
 Net weight : 32.8 oz. / 930 g

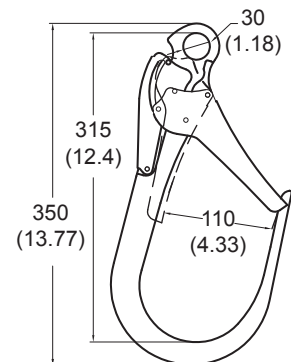

mm (inch)

Anodized

**N-50110X
Aluminum Huge Rebar Hook**

Forged aluminum alloy
 Min. Breaking load : 4500 lbs / 20 kN
 Meets :
 ● EN 362 : 2004
 Net weight : 32.8 oz. / 930 g

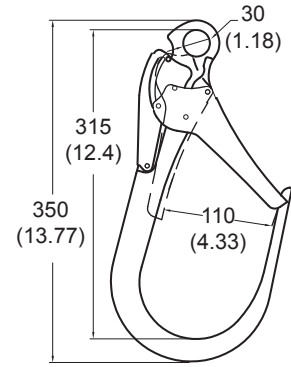

mm (inch)

Anodized

**N-5015
Aluminum Indicator Swivel Rebar Hook**

Forged aluminum alloy
 Min. Breaking load : 5000 lbs / 23 kN
 Meets :
 ● EN 362 : 2004
 Net weight : 18.66 oz. / 529 g

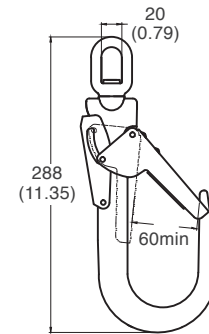

mm (inch)

Anodized

**N-5015 / 0
Aluminum Swivel Rebar Hook (non - Indicator)**

Forged aluminum alloy
 Min. Breaking load : 5000 lbs / 23 kN
 Meets :
 ● EN 362 : 2004
 Net weight : 18.66 oz. / 529 g

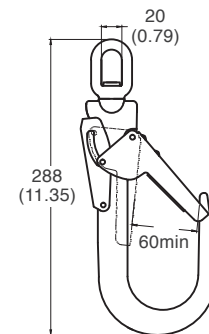

mm (inch)

Anodized

**N-5018
Aluminum Rebar Hook**

Forged aluminum alloy
 Min. Breaking load : 5000 lbs / 23 kN
 Meets :
 ● EN 362 : 2004
 Net weight : 9.2 oz. / 260 g

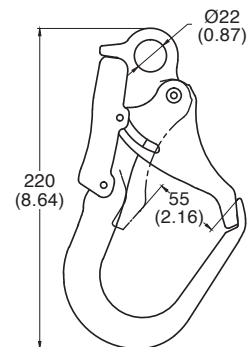

mm (inch)

Anodized

**N-5051
Flexigrip-Connectcor**

Aluminum, Wire rope
 Min. Breaking load : 5000 lbs / 23 kN
 Meets:
 ● EN 362 : 2004
 Net weight : 9.2 oz. / 263 g

New

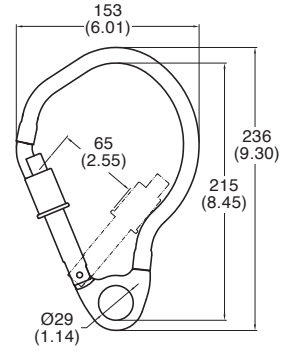

Anodized

mm (inch)

Aluminum Components



N-503 Aluminum Snap Hook

Forged aluminum alloy
 Min. Breaking load : 5000 lbs / 23 kN
 Meets EN 362 : 2004
 Net weight : 4.5 oz. / 130 g

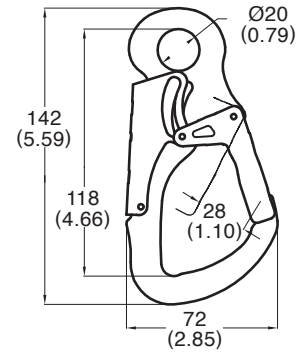

mm (inch)

Anodized

N-5032 Aluminum Snap Hook

Forged aluminum alloy
 Mini. Breaking load : 5000 lbs / 23 kN
 Meets EN 362 : 2004
 Net weight : 4.6 oz. / 134 g

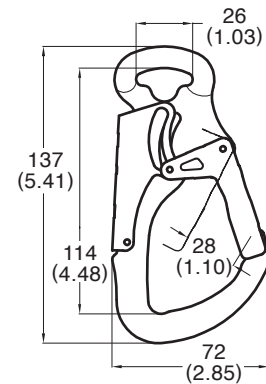

mm (inch)

Anodized

N-5035 Aluminum Indicator Swivel Snap Hook

Forged aluminum alloy
 Min. Breaking load : 5000 lbs / 23 kN
 Meets EN 362 : 2004
 Net weight : 6.4 oz. / 184 g

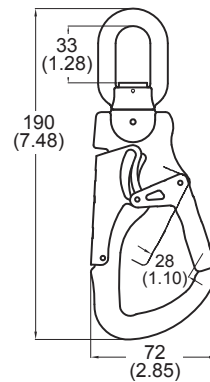

mm (inch)

Anodized

N-5035 / 0 Aluminum Swivel Snap Hook (non - Indicator)

Forged aluminum alloy
 Min. Breaking load : 5000 lbs / 23 kN
 Meets EN 362 : 2004
 Net weight : 6.3 oz. / 180 g

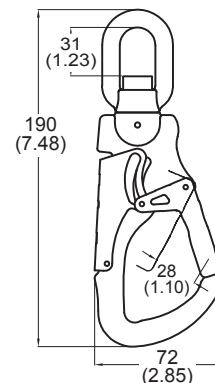

mm (inch)

Anodized

**N-528
Aluminum D-Ring**

Forged aluminum alloy
 100% proof loaded to 3600 lbs / 16 kN
 Min. Breaking load : 5000 lbs / 23 kN
 Meets :
 ● ANSI Z359.12-2019
 ● CSA Z259.12-16
 Net weight : 2.6 oz. / 75 g

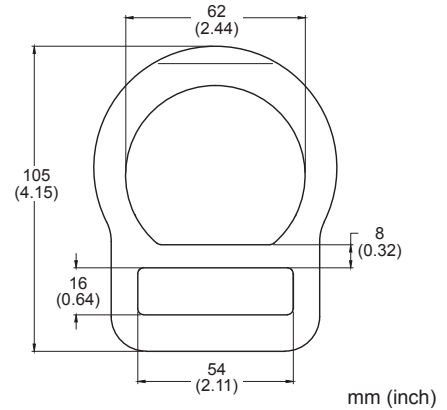

Anodized

**N-529
Aluminum Bent D-Ring**

Forged aluminum alloy
 100% proof loaded to 3600 lbs / 16 kN
 Min. Breaking load : 5000 lbs / 23 kN
 Meets :
 ● ANSI Z359.12-2019
 ● CSA Z259.12-16
 Net weight : 2.8 oz. / 78 g

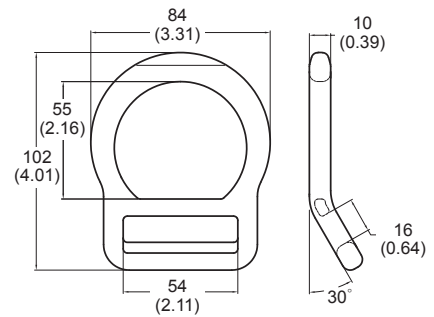

Anodized

**N-528A
Alum D-Ring-5M Middle Bar**

Forged aluminum alloy
 100% proof loaded to 3600 lbs / 16kN
 Min. Breaking load : 5000 lbs / 23 kN
 Meets :
 ● ANSI Z359.12-2019
 ● CSA Z259.12-16
 Net weight : 3.3 oz. / 94 g

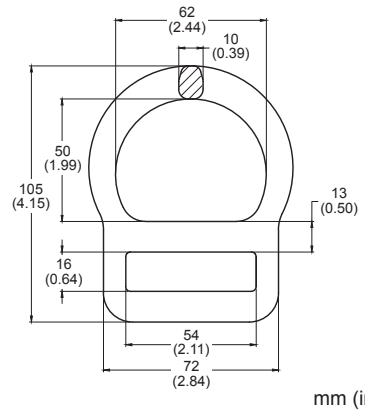

Anodized

**N-529A
Alum Bent D-Ring-5M Middle Bar**

Forged aluminum alloy
 100% proof loaded to 3600 lbs / 16kN
 Min. Breaking load : 5000 lbs / 23 kN
 Meets :
 ● ANSI Z359.12-2019
 ● CSA Z259.12-16
 Net weight : 3.3 oz. / 94 g

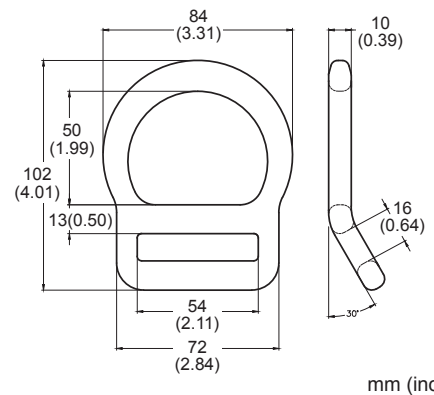

Anodized

N-518 Aluminum D-Ring

Forged aluminum alloy
 100% proof loaded to 3600 lbs / 16 kN
 Min. Breaking load : 5000 lbs / 23 kN
 Net weight : 2.7 oz. / 76 g

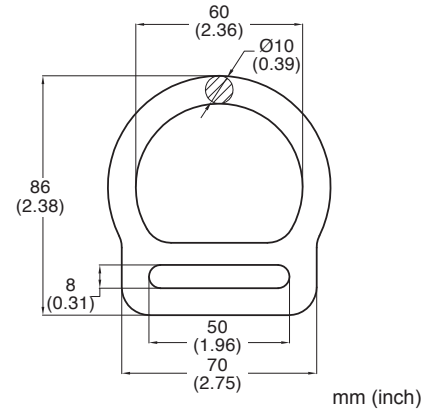

Anodized

N-519 Aluminum Bent D-Ring

Forged aluminum alloy
 100% proof loaded to 3600 lbs / 16 kN
 Min. Breaking load : 5000 lbs / 23 kN
 Net weight : 1.8 oz. / 74 g

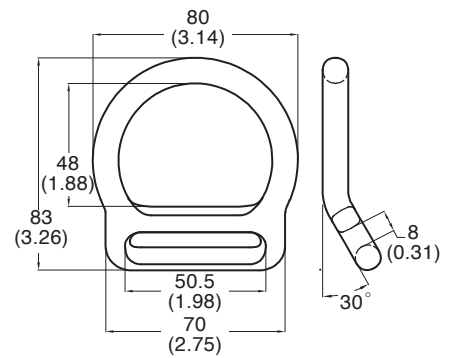

Anodized

N-5416 Aluminum D-Ring

Forged aluminum alloy
 100% proof loaded to 3600 lbs / 16 kN
 Min. Breaking load : 5000 lbs / 23 kN
 Meets :
 ● ANSI Z359.12-2019
 ● CSA Z259.12-16
 Net weight : 2.9 oz. / 83 g

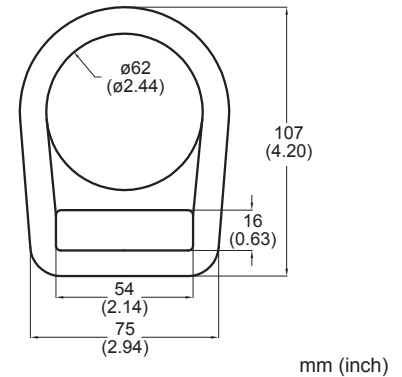

Anodized

N-540 Aluminum D-Ring

Forged aluminum alloy
 100% proof loaded to 3600 lbs / 16 kN
 Min. Breaking load : 5000 lbs / 23 kN
 Meets :
 ● ANSI Z359.12-2019
 ● CSA Z259.12-16
 Net weight : 4.0 oz. / 114 g

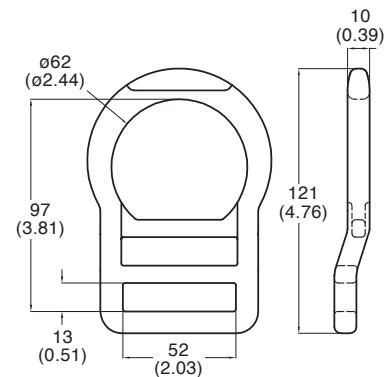

Anodized

**N-5203
Aluminum D-Ring**

Forged aluminum alloy
 100% proof loaded to 3600 lbs / 16 kN
 Min. Breaking load : 5000 lbs / 23 kN
 Meets :
 ● ANSI Z359.12-2019
 ● CSA Z259.12-16
 Net weight : 2.2 oz. / 62 g

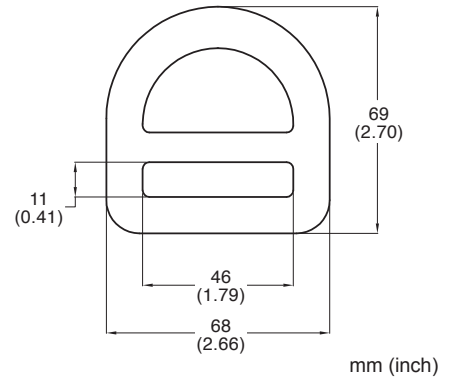

Anodized

**N-5204
Aluminum Bent D-Ring**

Forged aluminum alloy
 100% proof loaded to 3600 lbs / 16 kN
 Min. Breaking load : 5000 lbs / 23 kN
 Meets :
 ● ANSI Z359.12-2019
 ● CSA Z259.12-16
 Net weight : 1.9 oz. / 53 g

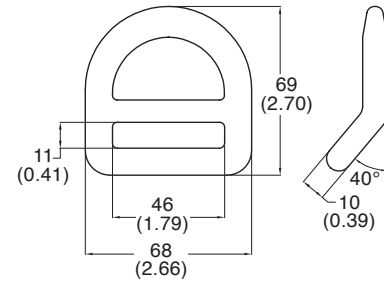

Anodized

**N-507
Aluminum D-Ring**

Forged aluminum alloy
 Min. Breaking load : 4000 lbs / 18 kN
 Net weight : 3.7 oz. / 106 g

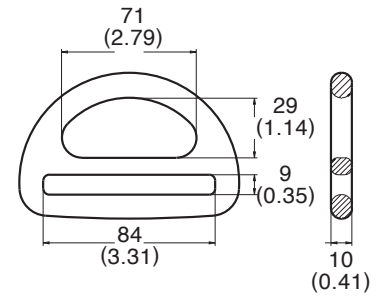

Anodized

**N-512
Aluminum D-Ring**

Forged aluminum alloy
 Min. Breaking load : 4000 lbs / 18 kN
 Net weight : 1.6 oz. / 44 g

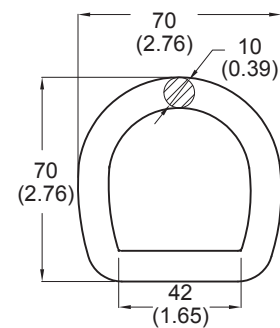

Anodized

N-5407 Aluminum D-Ring

Forged aluminum alloy
 100% proof loaded to 3600 lbs / 16 kN
 Min. Breaking load : 5000 lbs / 23 kN
 Meets :
 ● ANSI Z359.12-2019
 ● CSA Z259.12-16
 Net weight : 2.3 oz. / 65 g

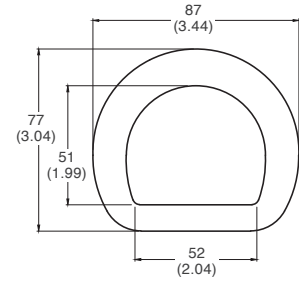

Anodized

mm (inch)

N-5407B Aluminum Bent D-Ring

Forged aluminum alloy
 100% proof loaded to 3600 lbs / 16 kN
 Min. Breaking load : 5000 lbs / 23 kN
 Meets :
 ● ANSI Z359.12-2019
 ● CSA Z259.12-16
 Net weight : 2.2 oz. / 64 g

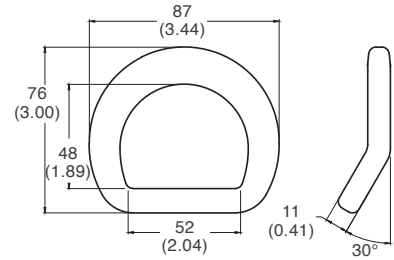

Anodized

mm (inch)

N-5019 Aluminum Quick Buckle

Sheet aluminum alloy
 Min. Breaking load : 2000 lbs / 9 kN
 Net weight : 0.3 oz. / 8g

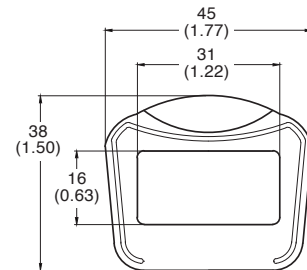

Anodized

mm (inch)

N-5020 Aluminum Quick Buckle

Sheet aluminum alloy
 Min. Breaking load: 2000 lbs / 9 kN
 Net weight: 0.2 oz./ 5 g

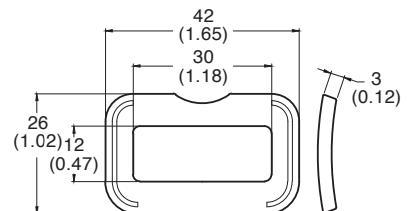

Anodized

mm (inch)

N-5719
Aluminum Quick Buckle

Sheet aluminum alloy
Min. Breaking load : 2000 lbs / 9 kN
Net weight : 0.2 oz. / 7 g

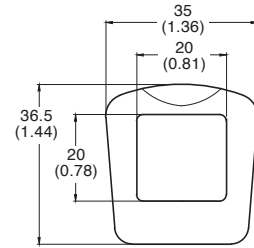

Anodized

mm (inch)

N-5721
Aluminum Quick Buckle

Sheet aluminum alloy
Min. Breaking load : 2000 lbs / 9 kN
Net weight : 0.2 oz. / 5 g

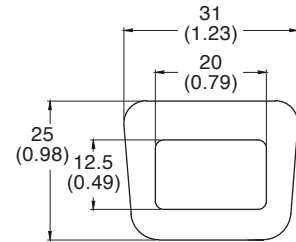

Anodized

mm (inch)

N-5720
Aluminum Quick Buckle

Sheet aluminum alloy
Min. Breaking load : 2000 lbs / 9 kN
Net weight : 0.39 oz. / 11 g

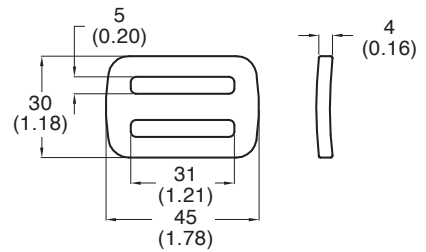

Anodized

mm (inch)

N-5722
Aluminum Quick Buckle

Sheet aluminum alloy
Min. Breaking load : 2000 lbs / 9 kN
Net weight : 0.35 oz. / 10 g

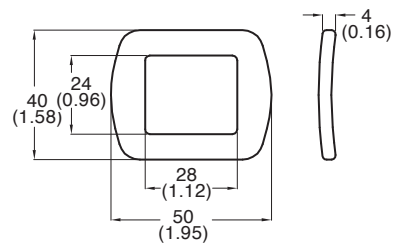

Anodized

mm (inch)

N-5740

Aluminum Quick Buckle

Sheet aluminum alloy
 Min. Breaking load : 2000 lbs / 9 kN
 Net weight : 0.46 oz. / 13 g

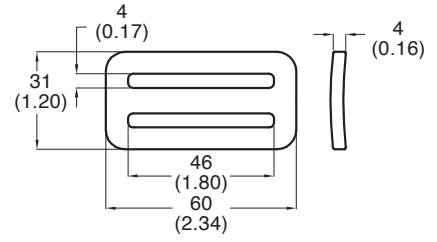

Anodized

mm (inch)

N-5741

Aluminum Quick Buckle

Sheet aluminum alloy
 Min. Breaking load : 3400 lbs / 15 kN
 Meets :
 ● ANSI Z359.12-2019
 ● CSA Z259.12-16
 Net weight : 0.49 oz. / 14 g

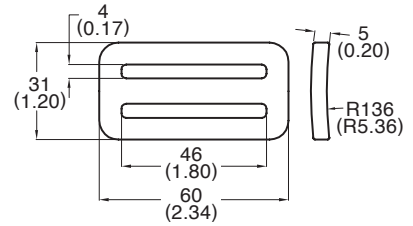

Anodized

mm (inch)

N-5742

Aluminum Quick Buckle

Sheet aluminum alloy
 Min. Breaking load : 3400 lbs / 15 kN
 Meets :
 ● ANSI Z359.12-2019
 ● CSA Z259.12-16
 Net weight : 0.42 oz. / 12 g

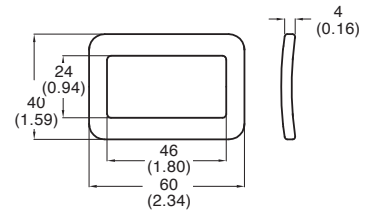

Anodized

mm (inch)

N-5748

Aluminum Quick Buckle

Sheet aluminum alloy
 Min. Breaking load : 3400 lbs / 15 kN
 Meets :
 ● ANSI Z359.12-2019
 ● CSA Z259.12-16
 Net weight : 0.95 oz. / 27 g

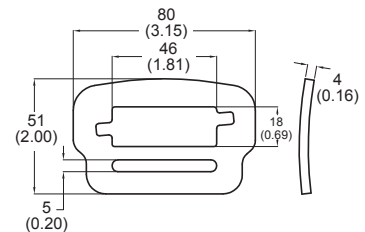

Anodized

mm (inch)

**N-509
Aluminum Long Adjuster**

Forged aluminum alloy
 Min. Breaking load : 2200 lbs / 11 kN
 Net weight : 2.0 oz. / 56 g

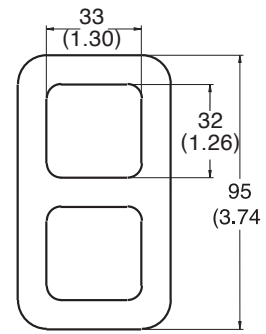

Anodized

mm (inch)

**N-508
Aluminum Adjuster**

Forged aluminum alloy
 Min. Breaking load : 4500 lbs / 20 kN
 Net weight : 1.3 oz. / 37 g

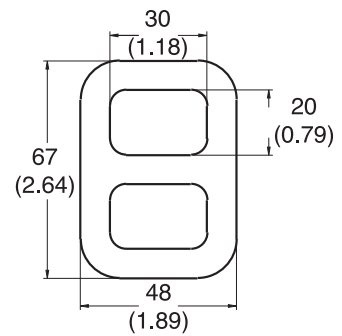

Anodized

mm (inch)

**N-511
Aluminum Tongue Buckle with double tongue**

Forged aluminum alloy
 Min. Breaking load : 4000 lbs / 18 kN
 Net weight : 2.0 oz. / 58 g

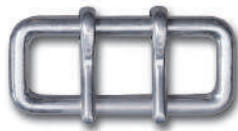

N-511



N-510

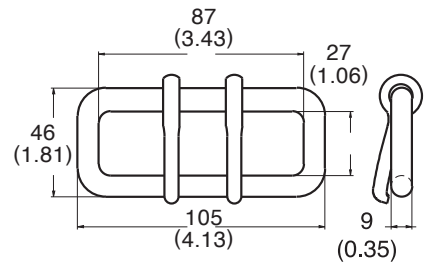

**N-510
Aluminum Loop only without double tongue**

Anodized

mm (inch)

**N-5439
Aluminum Tongue Buckle**

Forged aluminum alloy
 Min. Breaking load : 4000 lbs / 18 kN
 Meets :
 ● ANSI Z359.12-2019
 ● CSA Z259.12-16
 Net weight : 2.3 oz. / 67 g

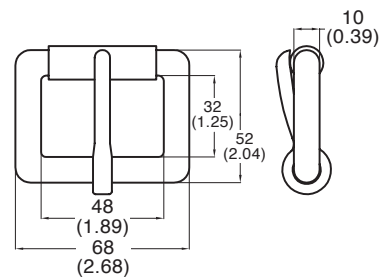

Anodized

mm (inch)

N-5212 Aluminum Adjuster Buckle

Forged aluminum alloy
 Min. Breaking load : 4000 lbs / 18 kN
 Meets :
 ● ANSI Z359.12-2019
 ● CSA Z259.12-16
 Net weight : 2.7 oz. / 76 g

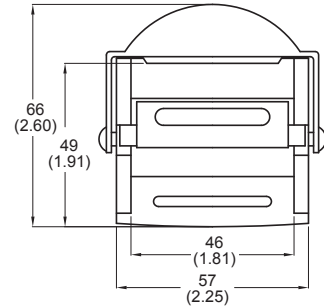

mm (inch)

Anodized

N-533 Aluminum Adjuster Buckle

Forged aluminum alloy
 Min. Breaking load : 4000 lbs / 18 kN
 Meets :
 ● ANSI Z359.12-2019
 ● CSA Z259.12-16
 Net weight : 1.9 oz. / 54 g

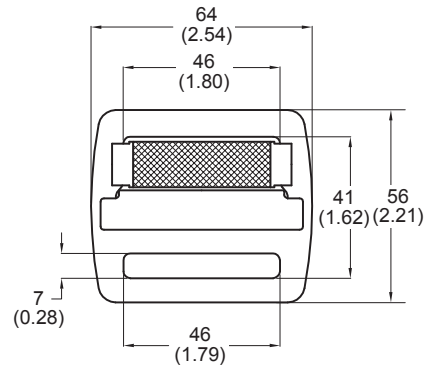

mm (inch)

Anodized

N-51428 / N-51445 / N-51460 Aluminum O Ring

Forged aluminum alloy
 100% proof loaded to 3600 lbs / 16kN
 Min. Breaking load : 5000 lbs / 23 kN
 Meets :
 ● ANSI Z359.12-2019
 ● CSA Z259.12-16

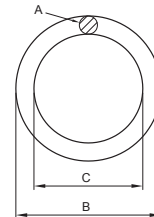

Art.No	Dimensions(mm)			Weight	
	A	B	C	(g)	(oz)
N-51428	ø12	52	28	38	1.3
N-51445	ø12	70	45	55	2.0
N-51460	ø10	80	60	50	1.8

mm (inch)

Anodized

N-51445A Open O Ring

Aluminum alloy, heat treated
 Min. Breaking load : 5000 lbs / 23 kN
 Net weight : 4.23 oz. / 120 g

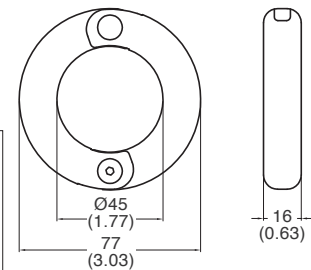

mm (inch)

Anodized

New

N-5877
Extra Lock Aluminum QR Buckle

Aluminum alloy

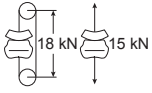

Meets :

- ANSI Z359.12-2019
- CSA Z259.12-16

Net weight : 4.6 oz. / 131 g

Patent US 9521882

Anodized

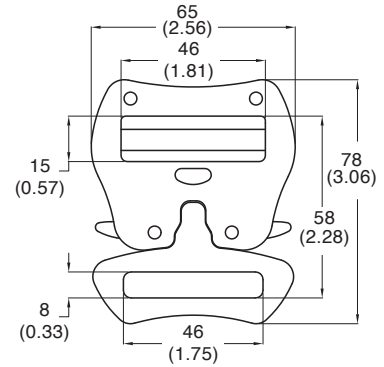
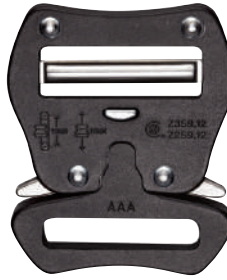

mm (inch)

N-5868
Aluminum QR Buckle

Aluminum alloy

Net weight : 1.82 oz. / 52 g

Anodized

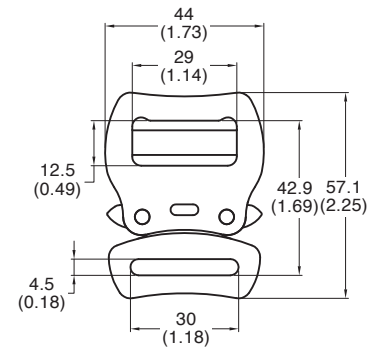

mm (inch)

N-5868T
Aluminum QR Buckle

Aluminum alloy

Net weight : 2.14 oz. / 61 g

Anodized

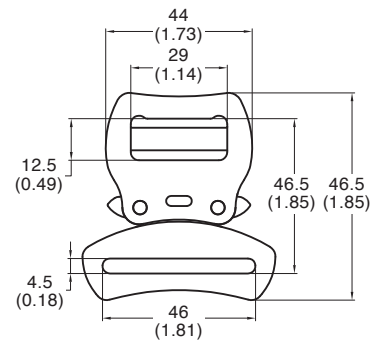

mm (inch)

N-5869T
Aluminum QR Buckle

Aluminum alloy

Net weight : 2.45 oz. / 70 g

Anodized

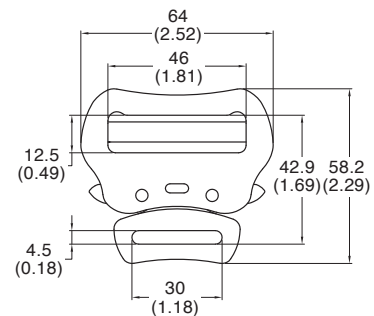

mm (inch)

N-5869 Aluminum QR Buckle

Aluminum alloy

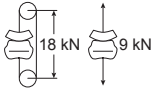

Net weight : 2.8 oz. / 79g

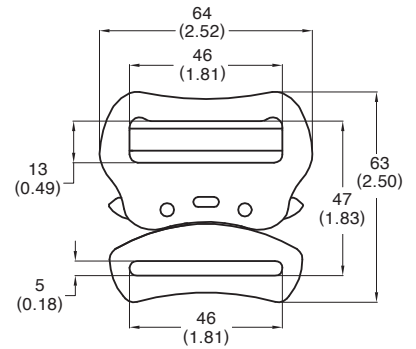

mm (inch)

Anodized

N-5869-DA Aluminum QR Buckle

Aluminum alloy

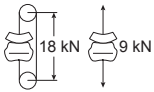

Net weight : 3.3 oz. / 93 g

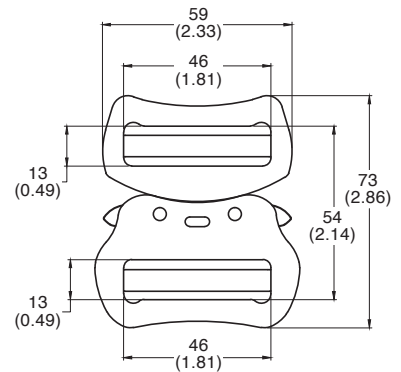
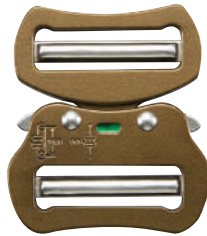

mm (inch)

Anodized

N-5870A Aluminum QR Buckle

Forged aluminum alloy

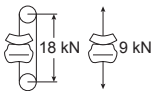

Net weight : 2.7 oz. / 76 g

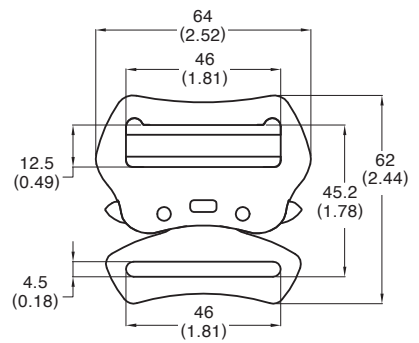

mm (inch)

Anodized

N-5871 Aluminum QR Buckle

Aluminum alloy

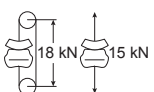

Meets :

- ANSI Z359.12-2019
- CSA Z259.12-16

Net weight : 3.2 oz. / 93 g

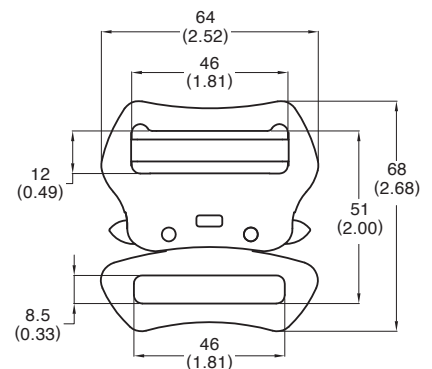

mm (inch)

Anodized

N-5876
QR Buckle with D Ring

Forged aluminum alloy

Meets:

- EN 358
- ANSI Z359.12-2019
- CSA Z259.12-16

Net weight : 7.94 oz. / 225 g

New

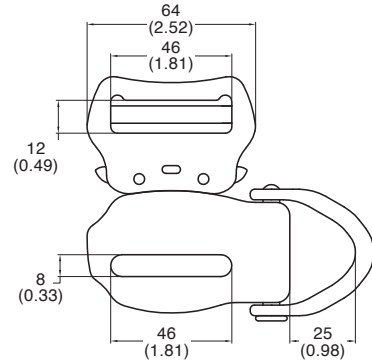

mm (inch)

Anodized

N-5860
QRA Buckle

Forged aluminum alloy

Min. Breaking load : 3372 lbs / 15 kN

Meets :

- ANSI Z359.12-2019
- CSA Z259.12-16

Net weight : 5.3 oz. / 150 g

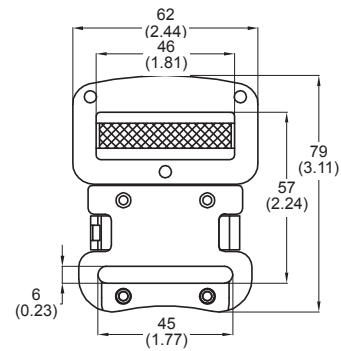

mm (inch)

Anodized

N-5861
QRA Buckle

Forged aluminum alloy

Min. Breaking load : 3372 lbs / 15 kN

Meets :

- ANSI Z359.12-2019
- CSA Z259.12-16

Net weight : 3.9 oz. / 110 g

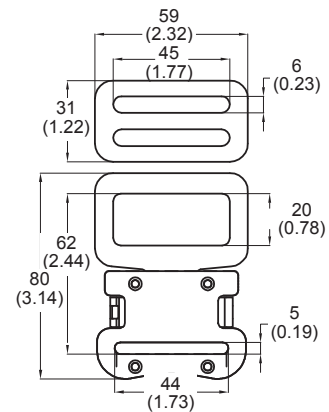
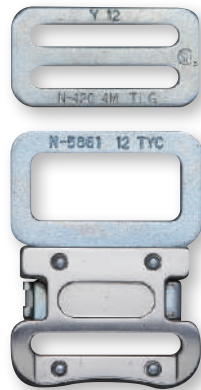

mm (inch)

Anodized

N-5862
QRA Buckle

Forged aluminum alloy

Min. Breaking Load : 3372 lbs / 15 kN

Meets :

- ANSI Z359.12-2019
- CSA Z259.12-16

Net weight : 3.5 oz. / 100 g

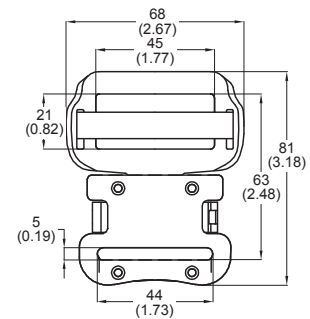

mm (inch)

Anodized

Aluminum Components



N-5867 QRA Buckle

Forged aluminum alloy
 Min. Breaking load : 2000 lbs / 9 kN
 Net weight : 3.6 oz. / 103 g

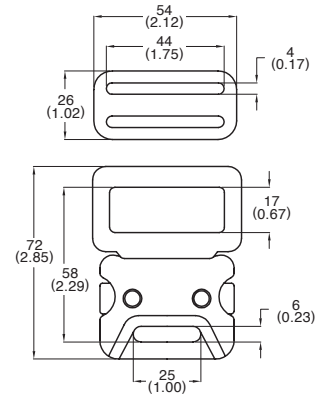

Anodized

mm (inch)

N-3591-S Swivels - jaw to jaw

Stainless Steel, SUS 304
 Min Breaking load : 5000 lbs / 23 kN
 Net weight : 2.5 oz. / 74 g

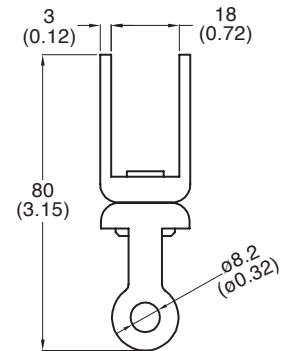

Polished

mm (inch)

N-904-S Anchorage Connector (5 / 8")

Stainless steel, SCS 11
 Min. Breaking load : 5000 lbs / 23 kN
 Net weight : 22.7 oz. / 645 g

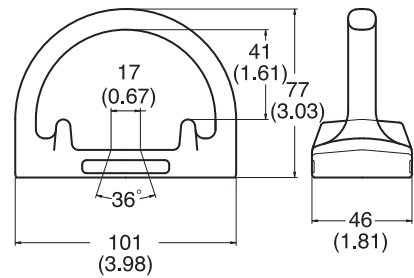

Polished

mm (inch)

N-430-S D-Ring, with bar

Stainless steel, SUS 304
 Min. Breaking load : 3600 lbs / 16 kN
 Net weight : 3.1 oz. / 90 g

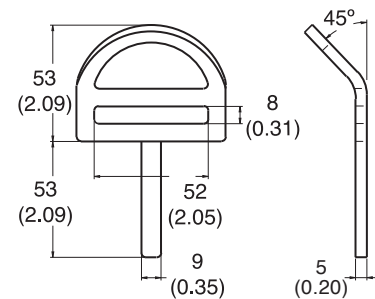

Polished

mm (inch)

**N-403-S
D-Ring**

Stainless steel, SUS 304
 100% proof loaded to 3600 lbs / 16 kN
 Min. Breaking load : 5000 lbs / 23 kN
 Meets :
 ● ANSI Z359.12-2019
 ● CSA Z259.12-16
 Net weight : 3.0 oz. / 85 g

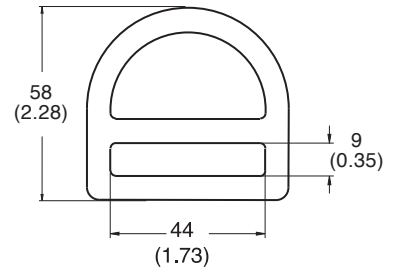

Polished

mm (inch)

**N-402-S
D-Ring**

Stainless steel, SUS 304
 Min. Breaking load : 5000 lbs / 23 kN
 Meets :
 ● ANSI Z359.12-2019
 ● CSA Z259.12-16
 Net weight : 3.5 oz. / 98 g

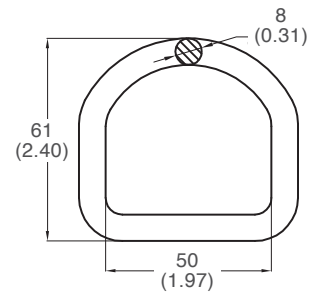

Polished

mm (inch)

**N-432-S
D-Ring**

Stainless steel, SUS 304
 Min. Breaking load : 4000 lbs / 18 kN
 Net weight : 2.8 oz. / 80 g

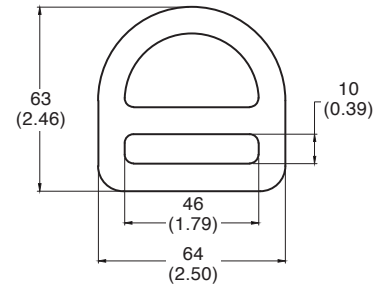

Polished

mm (inch)

**N-432A-S
D Ring**

Stainless steel, SUS 304
 Min. Breaking load : 5000 lbs / 23 kN
 Net weight : 2.8 oz. / 80 g

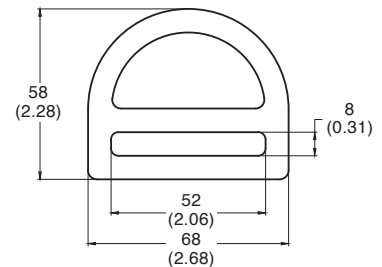

Polished

mm (inch)

**N-431-S
Bent D-Ring**

Stainless steel, SUS 304
 Min. Breaking load : 4000 lbs / 18 kN
 Net weight : 2.8 oz. / 80 g

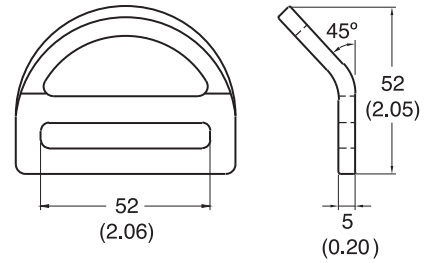

Polished

mm (inch)

**N-414-S
D-Ring**

Stainless steel, SUS 304
 100% proof loaded to 3600 lbs / 16 kN
 Min. Breaking load : 5000 lbs / 23 kN
 Meets :
 ● ANSI Z359.12-2019
 ● CSA Z259.12-16
 Net weight : 5.6 oz. / 159 g

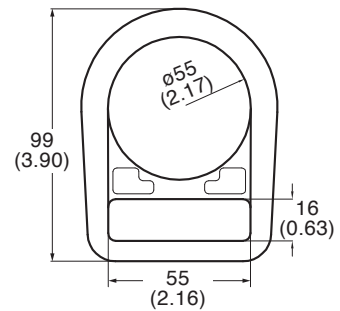

Polished

mm (inch)

**N-415-S
D-Ring**

Stainless steel, SUS 304
 100% proof loaded to 3600 lbs / 16 kN
 Min. Breaking load : 5000 lbs / 23 kN
 Meets :
 ● ANSI Z359.12-2019
 ● CSA Z259.12-16
 Net weight : 4.9 oz. / 140 g

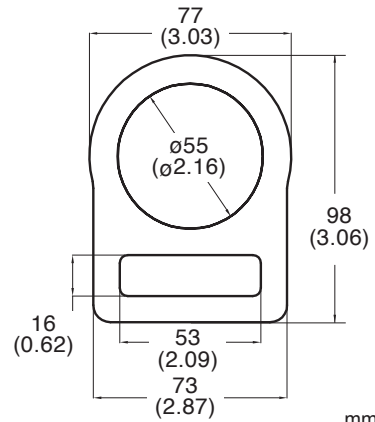

Polished

mm (inch)

**N-420-S
Quick Buckle**

Stainless steel, SUS 304
 Min. Breaking load : 4000 lbs / 18 kN
 Meets :
 ● ANSI Z359.12-2019
 ● CSA Z259.12-16
 Net weight : 1.0 oz. / 28 g

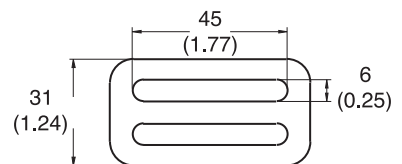

Polished

mm (inch)

**N-422-S
Quick Buckle**

Stainless steel, SUS 304
 Min. Breaking load : 4000 lbs / 18 kN
 Meets :
 ● ANSI Z359.12-2019
 ● CSA Z259.12-16
 Net weight : 1.1 oz. / 31 g

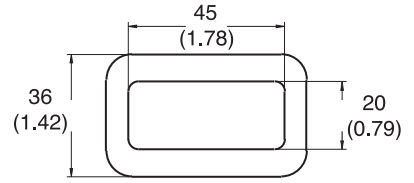

Polished

mm (inch)

**N-421-S
Quick Buckle**

Stainless steel, SUS 304
 Min. Breaking load : 4000 lbs / 18 kN
 Meets :
 ● ANSI Z359.12-2019
 ● CSA Z259.12-16
 Net weight : 1.8 oz. / 50 g

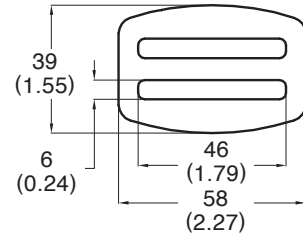

Polished

mm (inch)

**N-423-S
Quick Buckle**

Stainless steel, SUS 304
 Min. Breaking load : 4000 lbs / 18 kN
 Meets :
 ● ANSI Z359.12-2019
 ● CSA Z259.12-16
 Net weight : 2.4 oz. / 69 g

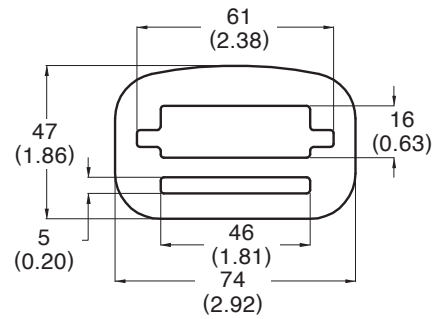

Polished

mm (inch)

**N-448-S
Quick Buckle**

Stainless steel, SUS 304
 Min. Breaking load : 4000 lbs / 18 kN
 Meets :
 ● ANSI Z359.12-2019
 ● CSA Z259.12-16
 Net weight : 2.4 oz. / 69 g

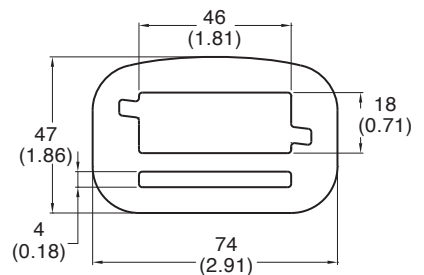

Polished

mm (inch)

Stainless steel Components



N-244-0-S Carabiner

Stainless steel, SUS 304
 Min. Breaking load : 5000 lbs / 23 kN
 Meets :
 ● EN 362 : 2004
 Net weight : 6.0 oz. / 169 g

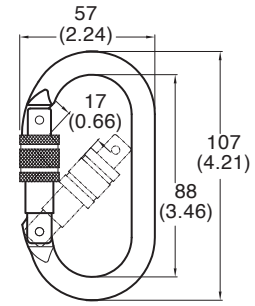

Polished

mm (inch)

N-252-S Carabiner

Stainless steel, SUS 304
 Min. Breaking load : 5000 lbs / 23 kN
 Meets :
 ● EN 362 : 2004
 Net weight : 9.0 oz. / 255 g

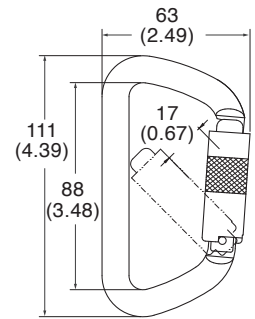

Polished

mm (inch)

N-268G-S Carabiner 3600 LBS gate strength

Stainless steel, SUS 420
 100% proof loaded to 3600 lbs / 16 kN
 Min. Breaking load : 5000 lbs / 23 kN
 Meets:
 ● ANSI Z359.12-2019
 ● CSA Z259.12-16
 ● EN362 : 2004

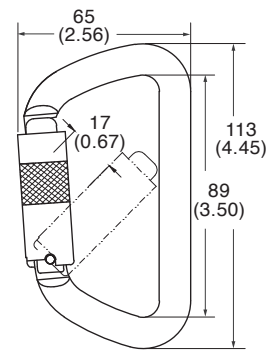

Art. No.	3600 Lbs Gate Strength	Gate Feature		Body
		Twist Locking	Triple Locking	Captive Pin
N-268G-CP-S	✓	✓		✓
N-268G-TRCP-S	✓		✓	✓

Net weight : 8.9 oz. / 254 g
 Zinc Plated

mm (inch)

N-3610-S
Rope Snap Hook
3600 LBS gate strength

Forged Stainless steel, SUS 420
 100% proof loaded to 3600 lbs / 16 kN
 Min. Breaking load : 5000 lbs / 23 kN
 Meets :
 ● ANSI Z359.12-2019
 ● CSA Z259.12-16
 Net weight : 13.7 oz. / 391 g

Zinc Plated

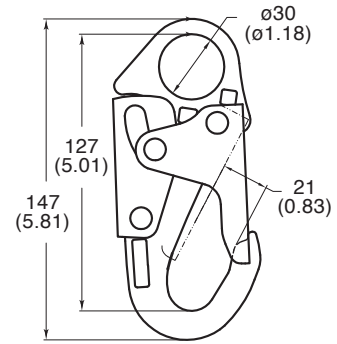

mm (inch)

N-3615-S
Indicator Swivel Snap Hook
3600 LBS gate strength

Forged Stainless steel, SUS 420
 100% proof loaded to 3600 lbs / 16 kN
 Min. Breaking load : 5000 lbs / 23 kN
 Meets :
 ● ANSI Z359.12-2019
 ● CSA Z259.12-16
 Net weight : 18.0 oz. / 514 g

Zinc Plated



Indicator activation

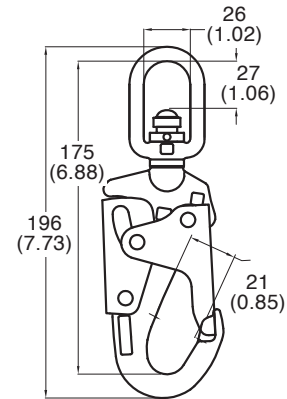

mm (inch)

N-3616-S
Swivel Snap Hook
3600 LBS gate strength
(non-Indicator)

Forged stainless Steel, SUS 420
 100% proof loaded to 3600 lbs / 16 kN
 Min. Breaking load : 5000 lbs / 23 kN
 Meets :
 ● ANSI Z359.12-2019
 ● CSA Z259.12-16
 Net weight : 17.6 oz. / 504 g

Zinc plated

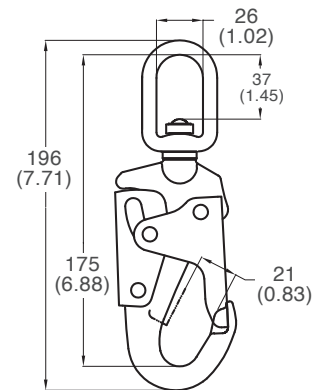

mm (inch)



100% proof loaded to 3600 lbs / 16 kN
Min. Breaking load : 5000 lbs / 23 kN
Meets ANSI Z359.12-2019 CSA Z259.12-16 EN 362:2004



YOKE offers an expanded range of carabiners including Aluminum and Steel options.

YOKE also offers carabiners in four different versions catering to a wide range of workplace requirements :

- Twist lock gate
- Screw lock gate
- Triple lock gate
- With or Without captive pin

YOKE Aluminum & Steel Carabiners with a "G" designation are compliant with ANSI/CSA standards offering a gate strength of 3600 lbs.

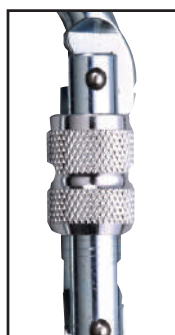
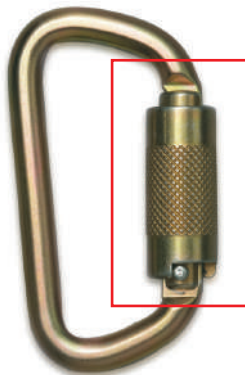
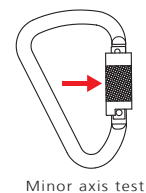
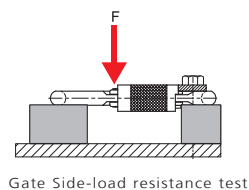
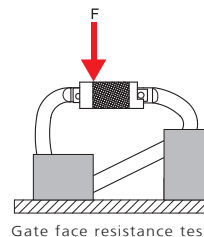

Screw Gate



Twist Locking



Triple Locking (TR)



Captive Pin (CP)

Nose Design



The "SNAG FREE" icon means that the carabiner body / gate has a smooth notch where the nose of the carabiner and gate meet. This smooth area prevents the carabiner from becoming 'snagged' on attachment points such as webbing, d-ring, etc.

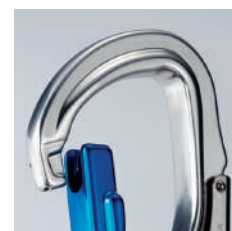

YOKE carabiners are tested by :

100% proof loaded to 3600 lbs / 16 kN
Min. Breaking load : 5000 lbs / 23 kN
Meets ANSI Z359.12-2019 CSA Z259.12-16 EN 362:2004



N-250GK

Steel Carabiner 3600 LBS gate strength

Alloy steel, heat treated

Art. No.	3600 Lbs Gate Strength	Gate Feature			Body
		Screw gate	Twist Locking	Triple Locking	Captive Pin
N-250GK	✓		✓		
N-250GK-TR	✓			✓	
N-250GK-CP	✓		✓		✓
N-250GK-TRCP	✓			✓	✓

Zinc Plated

Net weight : 7.6 oz. / 216 g

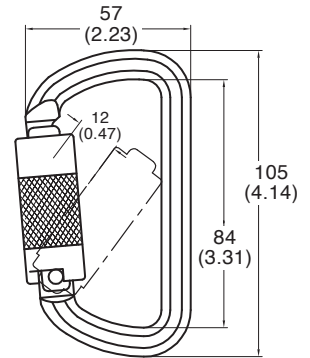
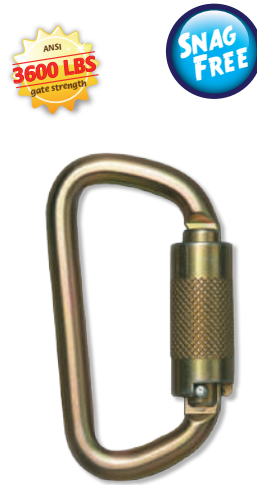

mm (inch)

N-250G

Steel Carabiner 3600 LBS gate strength

Alloy steel, heat treated

Art. No.	3600 Lbs Gate Strength	Gate Feature			Body
		Screw gate	Twist Locking	Triple Locking	Captive Pin
N-250-0		✓			
N-250			✓		
N-250G	✓		✓		
N-250G-TR	✓			✓	
N-250G-CP	✓		✓		✓
N-250G-TRCP	✓			✓	✓

Zinc Plated

Net weight : 7.6 oz. / 215 g.

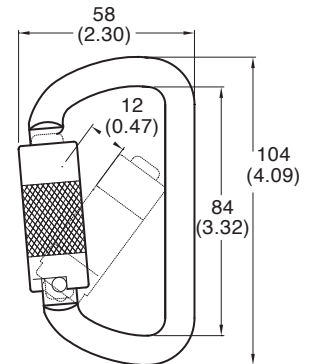

mm (inch)

N-244G

Steel Carabiner 3600 LBS gate strength

Alloy steel, heat treated

Art. No.	3600 Lbs Gate Strength	Gate Feature			Body
		Screw gate	Twist Locking	Triple Locking	Captive Pin
N-244-0		✓			
N-244			✓		
N-244G	✓		✓		
N-244G-TR	✓			✓	
N-244G-CP	✓		✓		✓
N-244G-TRCP	✓			✓	✓

Zinc Plated

Net weight : 7.6 oz. / 215 g.

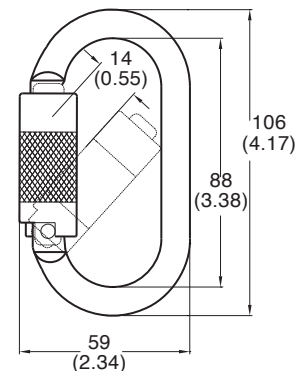

mm (inch)

100% proof loaded to 3600 lbs / 16 kN
Min. Breaking load : 5000 lbs / 23 kN
Meets ANSI Z359.12-2019 CSA Z259.12-16 EN 362:2004



N-252GK

Steel Carabiner 3600 LBS gate strength

Alloy steel, heat treated

Art. No.	3600 Lbs Gate Strength	Gate Feature			Body
		Screw gate	Twist Locking	Triple Locking	Captive Pin
N-252GK	✓		✓		
N-252GK -TR	✓			✓	
N-252GK -CP	✓		✓		✓
N-252GK -TRCP	✓			✓	✓

Zinc Plated

Net weight : 8.8 oz. / 252 g.

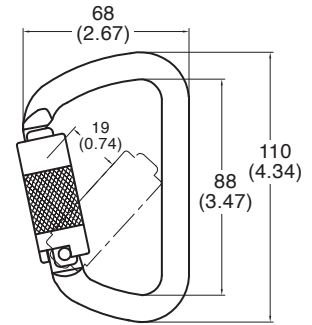

mm (inch)

N-252G

Steel Carabiner 3600 LBS gate strength

Alloy steel, heat treated

Art. No.	3600 Lbs Gate Strength	Gate Feature			Body
		Screw gate	Twist Locking	Triple Locking	Captive Pin
N-252-0		✓			
N-252			✓		
N-252G	✓		✓		
N-252G-TR	✓			✓	
N-252G-CP	✓		✓		✓
N-252G-TRCP	✓			✓	✓

Zinc Plated

Net weight : 8.8 oz. / 250 g.

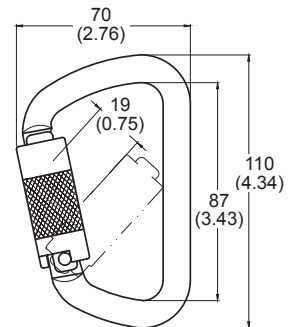

mm (inch)

N-256G

Steel Carabiner 3600 LBS gate strength

Alloy steel, heat treated

Art. No.	3600 Lbs Gate Strength	Gate Feature			Body
		Screw gate	Twist Locking	Triple Locking	Captive Pin
N-256-0		✓			
N-256			✓		
N-256G	✓		✓		
N-256G-TR	✓			✓	
N-256G-CP	✓		✓		✓
N-256G-TRCP	✓			✓	✓

Zinc Plated

Net weight : 9.8 oz. / 279 g.

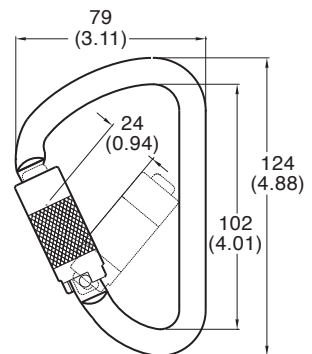

mm (inch)

YOKE carabiners are tested by :

100% proof loaded to 3600 lbs / 16 kN
Min. Breaking load : 5000 lbs / 23 kN
Meets ANSI Z359.12-2019 CSA Z259.12-16 EN 362:2004



N-245G

Steel Carabiner 3600 LBS gate strength

Alloy steel, heat treated

Art. No.	3600 Lbs Gate Strength	Gate Feature			Body
		Screw gate	Twist Locking	Triple Locking	Captive Pin
N-245-0		✓			
N-245			✓		
N-245G	✓		✓		
N-245G-TR	✓			✓	
N-245G-CP	✓		✓		✓
N-245G-TRCP	✓			✓	✓

Zinc Plated

Net weight : 7.1 oz. / 200 g.

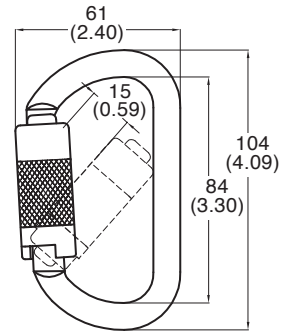

mm (inch)

N-251G

Steel Carabiner 3600 LBS gate strength

Alloy steel, heat treated

Art. No.	3600 Lbs Gate Strength	Gate Feature			Body
		Screw gate	Twist Locking	Triple Locking	Captive Pin
N-251-0		✓			
N-251			✓		
N-251G	✓		✓		
N-251G-TR	✓			✓	
N-251G-CP	✓		✓		✓
N-251G-TRCP	✓			✓	✓

Zinc Plated

Net weight : 8.0 oz. / 226 g.

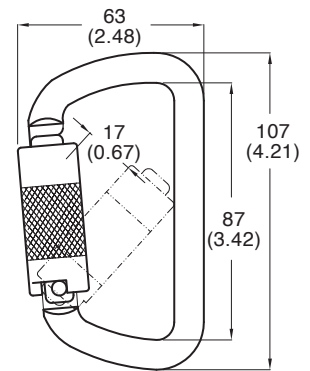
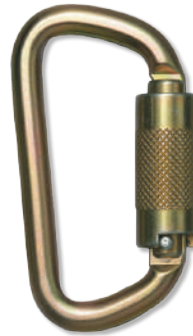

mm (inch)

N-268G

Steel Carabiner 3600 LBS gate strength

Alloy steel, heat treated

Art. No.	3600 Lbs Gate Strength	Gate Feature			Body
		Screw gate	Twist Locking	Triple Locking	Captive Pin
N-268-0		✓			
N-268			✓		
N-268G	✓		✓		
N-268G-TR	✓			✓	
N-268G-CP	✓		✓		✓
N-268G-TRCP	✓			✓	✓

Zinc Plated

Net weight : 9.9 oz. / 280 g.

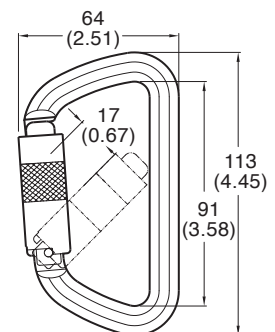

mm (inch)

100% proof loaded to 3600 lbs / 16 kN
Min. Breaking load : 5000 lbs / 23 kN
Meets ANSI Z359.12-2019 CSA Z259.12-16 EN 362:2004



N-267G

Steel Carabiner 3600 LBS gate strength

Alloy steel, heat treated

Art. No.	3600 Lbs Gate Strength	Gate Feature			Body
		Screw gate	Twist Locking	Triple Locking	Captive Pin
N-267-0		✓			
N-267			✓		
N-267G	✓		✓		
N-267G-TR	✓			✓	
N-267G-CP	✓		✓		✓
N-267G-TRCP	✓			✓	✓

Zinc Plated

Net weight : 7.7 oz. / 219 g.

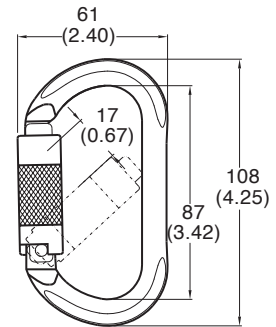

mm (inch)

N-246G

Steel Carabiner 3600 LBS gate strength

Alloy steel, heat treated

Art. No.	3600 Lbs Gate Strength	Gate Feature			Body
		Screw gate	Twist Locking	Triple Locking	Captive Pin
N-246-0		✓			
N-246			✓		
N-246G	✓		✓		
N-246G-TR	✓			✓	
N-246G-CP	✓		✓		✓
N-246G-TRCP	✓			✓	✓

Zinc Plated

Net weight : 10.1 oz. / 288 g.

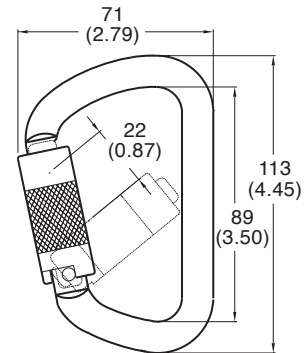

mm (inch)

N-254G

Steel Carabiner 3600 LBS gate strength

Alloy steel, heat treated

Art. No.	3600 Lbs Gate Strength	Gate Feature			Body
		Screw gate	Twist Locking	Triple Locking	Captive Pin
N-254-0		✓			
N-254-CP			✓		✓
N-254-TRCP				✓	✓
N-254G	✓		✓		
N-254G-TR	✓			✓	
N-254G-CP	✓		✓		✓
N-254G-TRCP	✓			✓	✓

Zinc Plated

Net weight : 12.9 oz. / 369 g.

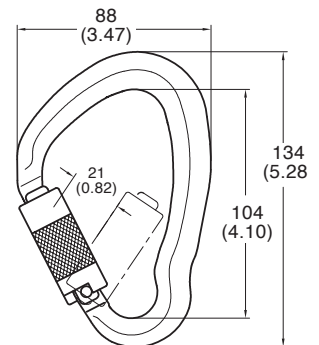

mm (inch)

YOKE carabiners are tested by :

100% proof loaded to 3600 lbs / 16 kN
Min. Breaking load : 5000 lbs / 23 kN
Meets ANSI Z359.12-2019 CSA Z259.12-16 EN 362:2004



N-248G

Steel Carabiner 3600 LBS gate strength

Alloy steel, heat treated

Art. No.	3600 Lbs Gate Strength	Gate Feature			Body Captive Pin
		Screw gate	Twist Locking	Triple Locking	
N-248-0		✓			
N-248			✓		
N-248G	✓		✓		
N-248G-TR	✓			✓	
N-248G-CP	✓		✓		✓
N-248G-TRCP	✓			✓	✓

Zinc Plated

Net weight : 10.5 oz. / 299 g.

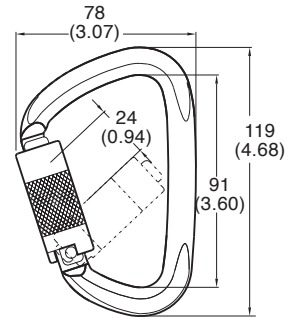

mm (inch)

N-261G

Steel Carabiner 3600 LBS gate strength

Alloy steel, heat treated

Art. No.	3600 Lbs Gate Strength	Gate Feature		
		Screw gate	Twist Locking	Triple Locking
N-261-0		✓		
N-261			✓	
N-261G	✓		✓	
N-261G-TR	✓			✓

Zinc Plated

Net weight : 10.7 oz. / 305 g.

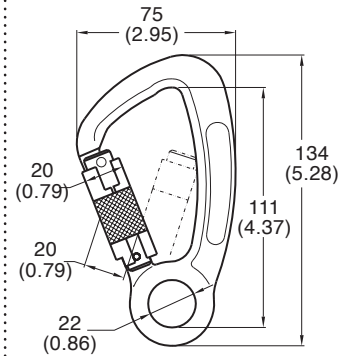

mm (inch)

N-2615G

Indicator Swivel Steel Carabiner

3600 LBS gate strength

Alloy steel, heat treated

Art. No.	3600 Lbs Gate Strength	Gate Feature		
		Screw gate	Twist Locking	Triple Locking
N-2615-0		✓		
N-2615			✓	
N-2615G	✓		✓	
N-2615G-TR	✓			✓

Zinc Plated

Net weight : 14.9 oz. / 423 g.

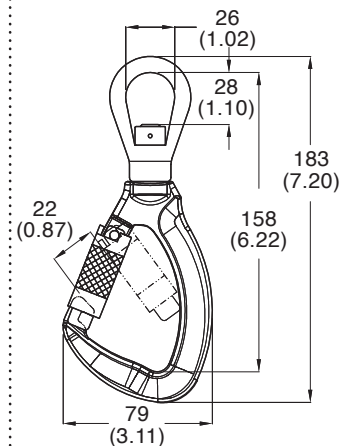

mm (inch)

100% proof loaded to 3600 lbs / 16 kN
Min. Breaking load : 5000 lbs / 23 kN
Meets ANSI Z359.12-2019 CSA Z259.12-16 EN 362:2004



N-247G-CP

Steel Carabiner 3600 LBS gate strength

Alloy steel, heat treated

Art. No.	3600 Lbs Gate Strength	Gate Feature			Body
		Screw gate	Twist Locking	Triple Locking	Captive Pin
N-247-0		✓			
N-247			✓		
N-247G-CP	✓		✓		✓
N-247G-TRCP	✓			✓	✓

Zinc Plated

Net weight : 11.0 oz. / 313 g.

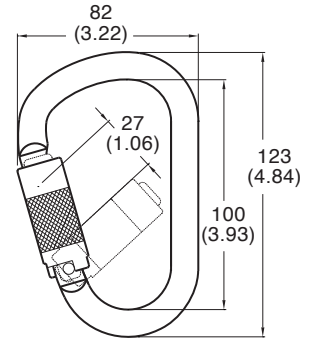

mm (inch)

N-258G-CP

Steel Carabiner 3600 LBS gate strength

Alloy steel, heat treated

Art. No.	3600 Lbs Gate Strength	Gate Feature			Body
		Screw gate	Twist Locking	Triple Locking	Captive Pin
N-258			✓		
N-258G-CP	✓		✓		✓
N-258G-TRCP	✓			✓	✓

Zinc Plated

Net weight : 22.0 oz. / 625 g.

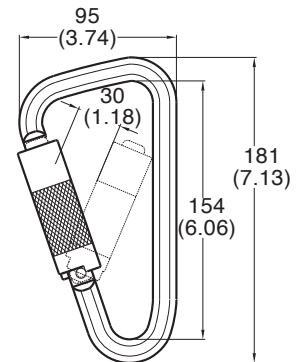

mm (inch)

N-263G-CP

Steel Carabiner 3600 LBS gate strength

Alloy steel, heat treated

Art. No.	3600 Lbs Gate Strength	Gate Feature			Body
		Screw gate	Twist Locking	Triple Locking	Captive Pin
N-263-0		✓			
N-263			✓		
N-263G-CP	✓		✓		✓
N-263G-TRCP	✓			✓	✓

Zinc Plated

Net weight : 15.8 oz. / 447 g.

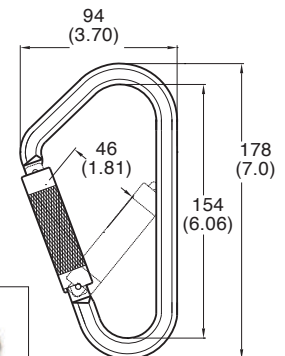

mm (inch)

YOKE carabiners are tested by :

100% proof loaded to 3600 lbs / 16 kN
Min. Breaking load : 5000 lbs / 23 kN
Meets ANSI Z359.12-2019 CSA Z259.12-16 EN 362:2004



N-259G-CP

Steel Carabiner 3600 LBS gate strength

Alloy steel, heat treated



Art. No.	3600 Lbs Gate Strength	Gate Feature			Body
		Screw gate	Twist Locking	Triple Locking	Captive Pin
N-259			✓		
N-259G-CP	✓		✓		✓
N-259G-TRCP	✓			✓	✓

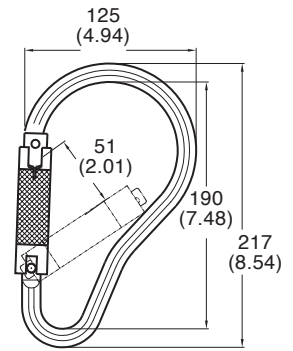

Zinc Plated

Net weight : 27.3 oz. / 774 g.

mm (inch)

N-265G-CP

Steel Carabiner 3600 LBS gate strength

Alloy steel, heat treated



Art. No.	3600 Lbs Gate Strength	Gate Feature			Body
		Screw gate	Twist Locking	Triple Locking	Captive Pin
N-265			✓		
N-265G-CP	✓		✓		✓
N-265G-TRCP	✓			✓	✓

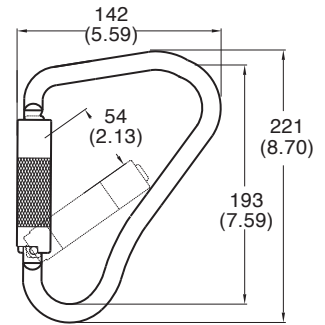

Zinc Plated

Net weight : 28.8 oz. / 817 g.

mm (inch)

mm (inch)

Steel Carabiner

Art. NO.	N-250G	N-244G	N-245G	N-251G	N-267G	N-252G	N-246G	N-268G	N-248G
Ø mm (inch)	10 (0.39)	10 (0.39)	10 (0.39)	10 (0.39)	10 (0.39)	11 (0.43)	12 (0.47)	12 (0.47)	12 (0.47)
Breaking load minimum (kN)	40	25	25	30	30	41	45	50	50
Gate opening mm (inch)	12 (0.47)	14 (0.55)	15 (0.59)	17 (0.67)	17 (0.67)	19 (0.75)	22 (0.87)	17 (0.67)	24 (0.94)
O.L. mm (inch)	104 (4.09)	106 (4.17)	106 (4.17)	107 (4.21)	108 (4.25)	111 (4.37)	113 (4.45)	113 (4.45)	119 (4.68)

Steel Carabiner

Art. NO.	N-247G	N-256G	N-254G	N-261G	N-263G	N-258G	N-2615G	N-259G	N265G
Ø mm (inch)	12 (0.47)	11 (0.43)	18 (0.71)	--	12 (0.47)	14 (0.55)	--	14 (0.55)	14 (0.55)
Breaking load minimum (kN)	30	45	50	45	35	50	35	35	45
Gate opening mm (inch)	27 (1.06)	24 (0.94)	21 (0.82)	20 (0.79)	46 (1.81)	30 (1.18)	22 (0.87)	51 (2.01)	54 (2.13)
O.L. mm (inch)	123 (4.84)	124 (4.88)	134 (5.28)	134 (5.28)	178 (7.01)	181 (7.13)	183 (7.20)	217 (8.54)	221 (8.70)





N-281
Aluminum Carabiner
 Aluminum alloy, SAE 7075

Art. No.	Gate Feature			Body
	Screw Gate	Twist Locking	Triple Locking	Captive Pin
N-281-0	✓			
N-281		✓		
N-281-TR			✓	
N-281-CP		✓		✓
N-281-TRCP			✓	✓

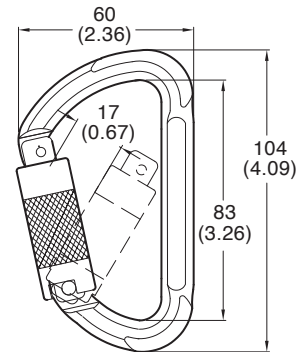

Anodized Net weight : 2.3 oz. / 66 g.

mm (inch)

N-271
Aluminum Carabiner
 Aluminum alloy, SAE 7075

Art. No.	Gate Feature			Body
	Screw Gate	Twist Locking	Triple Locking	Captive Pin
N-271-0	✓			
N-271		✓		
N-271-TR			✓	
N-271-CP		✓		✓
N-271-TRCP			✓	✓

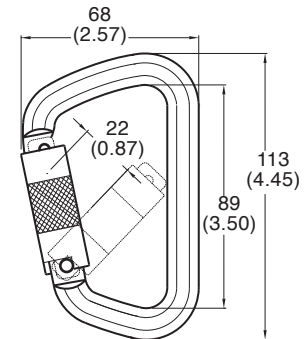

Anodized Net weight : 3.4 oz. / 96 g.

mm (inch)

YOKE Aluminum carabiners are tested by :

Min. Breaking load : 5000 lbs / 23 kN
Meets EN 362:2004



N-282
Aluminum Carabiner

Aluminum alloy, SAE 7075

Art. No.	Gate Feature			Body
	Screw Gate	Twist Locking	Triple Locking	Captive Pin
N-282-0	✓			
N-282		✓		
N-282-TR			✓	
N-282-CP		✓		✓
N-282-TRCP			✓	✓

Anodized Net weight : 3.0 oz. / 86 g.

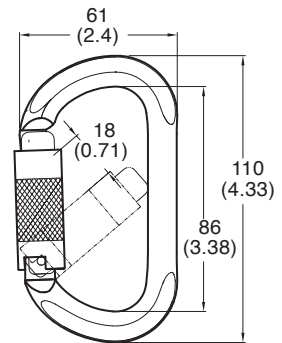

mm (inch)

N-283
Aluminum Carabiner

Aluminum alloy, SAE 7075

Art. No.	Gate Feature			Body
	Screw Gate	Twist Locking	Triple Locking	Captive Pin
N-283-0	✓			
N-283		✓		
N-283-TR			✓	
N-283-CP		✓		✓
N-283-TRCP			✓	✓

Anodized Net weight : 3.5 oz. / 98 g.

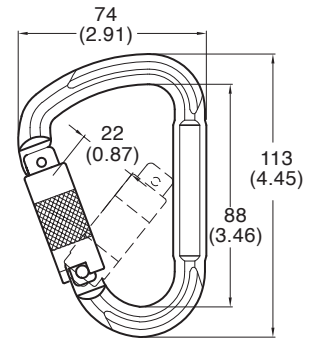

mm (inch)

N-284
Aluminum Carabiner

Aluminum alloy, SAE 7075

Art. No.	Gate Feature			Body
	Screw Gate	Twist Locking	Triple Locking	Captive Pin
N-284-0	✓			
N-284		✓		
N-284-TR			✓	
N-284-CP		✓		✓
N-284-TRCP			✓	✓

Anodized Net weight : 3.5 oz. / 98 g.

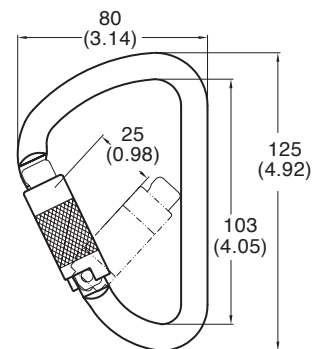

mm (inch)

N-274
Aluminum Carabiner

Aluminum alloy, SAE 7075

Art. No.	Gate Feature			Body
	Screw Gate	Twist Locking	Triple Locking	Captive Pin
N-274-0	✓			
N-274		✓		
N-274-TR			✓	
N-274-CP		✓		✓
N-274-TRCP			✓	✓

Anodized Net weight : 4.0 oz. / 114 g.

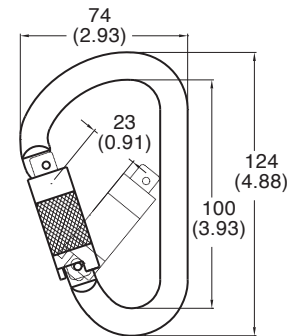

mm (inch)

N-272
Aluminum Carabiner

Aluminum alloy, SAE 7075

Art. No.	Gate Feature			Body
	Screw Gate	Twist Locking	Triple Locking	Captive Pin
N-272-0	✓			
N-272		✓		
N-272-TR			✓	
N-272-CP		✓		✓
N-272-TRCP			✓	✓

Anodized Net weight : 3.5 oz. / 98 g.

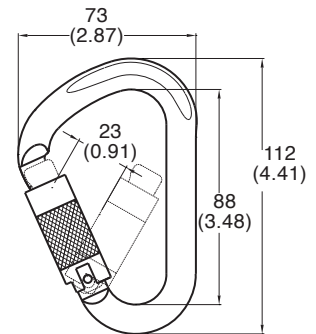

mm (inch)

N-276
Aluminum Carabiner

Aluminum alloy, SAE 7075

Art. No.	Gate Feature			Body
	Screw Gate	Twist Locking	Triple Locking	Captive Pin
N-276-0	✓			
N-276		✓		
N-276-TR			✓	
N-276-CP		✓		✓
N-276-TRCP			✓	✓

Anodized Net weight : 3.2 oz. / 91 g.

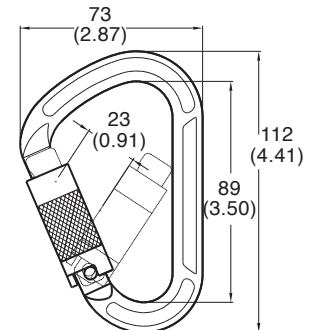

mm (inch)

YOKE Aluminum carabiners are tested by :

Min. Breaking load : 5000 lbs / 23 kN
Meets EN 362:2004



N-270 Aluminum Carabiner

Aluminum alloy, SAE 7075

Art. No.	Gate Feature			Body
	Screw Gate	Twist Locking	Triple Locking	Captive Pin
N-270-0	✓			
N-270		✓		
N-270-TR			✓	
N-270-CP		✓		✓
N-270-TRCP			✓	✓

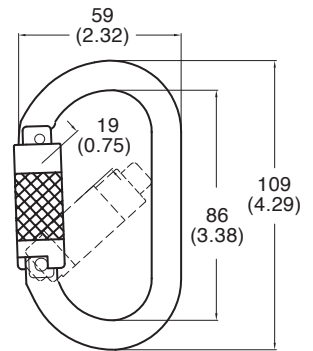

Anodized Net weight : 2.8 oz. / 78 g.

mm (inch)

N-273 Aluminum Carabiner

Aluminum alloy, SAE 7075

Art. No.	Gate Feature			Body
	Screw Gate	Twist Locking	Triple Locking	Captive Pin
N-273-0	✓			
N-273		✓		
N-273-TR			✓	
N-273-CP		✓		✓
N-273-TRCP			✓	✓

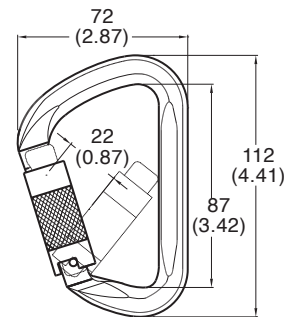

Anodized Net weight : 3.0 oz. / 86 g.

mm (inch)

N-275 Aluminum Carabiner

Aluminum alloy, SAE 7075

Art. No.	Gate Feature		
	Screw Gate	Twist Locking	Triple Locking
N-275-0	✓		
N-275		✓	
N-275-TR			✓

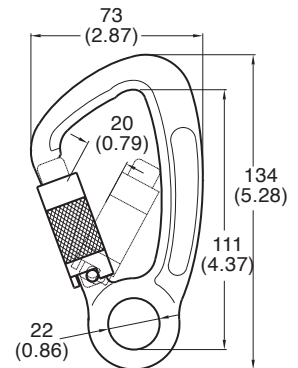

Anodized Net weight : 3.3 oz. / 93 g.

mm (inch)

**N-287
Aluminum Carabiner**

Aluminum alloy, SAE 7075

Art. No.	Gate Feature			Body
	Screw Gate	Twist Locking	Triple Locking	Captive Pin
N-287-0	✓			
N-287		✓		
N-287-TR			✓	
N-287-CP		✓		✓
N-287-TRCP			✓	✓

Anodized Net weight : 7.2 oz. / 205 g.

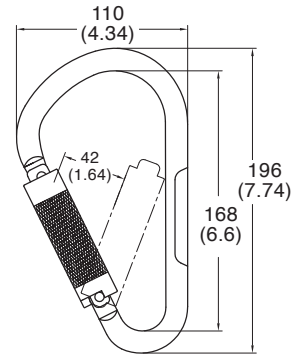

mm (inch)

**N-277
Aluminum Carabiner**

Aluminum alloy, SAE 7075

Art. No.	Gate Feature		Body
	Twist Locking	Triple Locking	Captive Pin
N-277-CP	✓		✓
N-277-TRCP		✓	✓

Anodized Net weight : 13.5 oz. / 384 g.

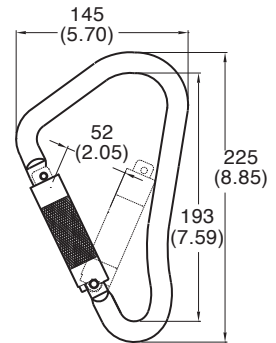

mm (inch)

**N-278
Aluminum Carabiner**

Aluminum alloy, SAE 7075

Art. No.	Gate Feature		Body
	Twist Locking	Triple Locking	Captive Pin
N-278-CP	✓		✓
N-278-TRCP		✓	✓

Anodized Net weight : 13.0 oz. / 368 g.

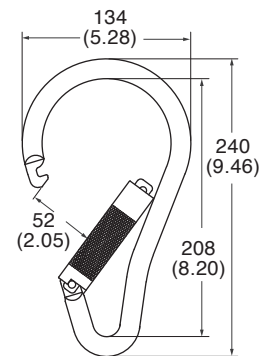

mm (inch)

YOKE Aluminum carabiners are tested by :

Min. Breaking load : 5000 lbs / 23 kN
Meets EN 362:2004



N-2750 Swivel Aluminum Carabiner

Aluminum alloy, SAE 7075

Art. No.	Gate Feature		
	Screw Gate	Twist Locking	Triple Locking
N-2750-0	✓		
N-2750		✓	
N-2750-TR			✓

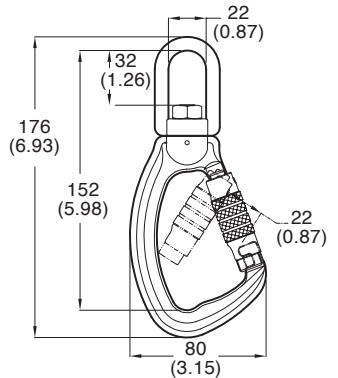

Anodized Net weight : 7.5 oz. / 214 g.

mm (inch)

N-2852 Aluminum Carabiner

Aluminum alloy, SAE 7075

Art. No.	Gate Feature			Body
	Screw Gate	Twist Locking	Triple Locking	Captive Pin
N-2852-0	✓			
N-2852		✓		
N-2852-TR			✓	
N-2852-CP		✓		✓
N-2852-TRCP			✓	✓

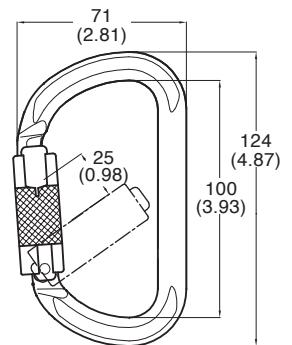

Anodized Net weight : 3.7 oz. / 108 g.

mm (inch)

N-2854 Aluminum Carabiner

Aluminum alloy, SAE 7075

Art. No.	Gate Feature			Body
	Screw Gate	Twist Locking	Triple Locking	Captive Pin
N-2854-0	✓			
N-2854		✓		
N-2854-TR			✓	
N-2854-CP		✓		✓
N-2854-TRCP			✓	✓

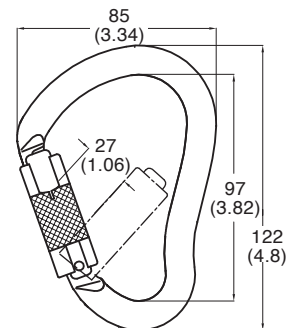

Anodized Net weight : 3.6 oz. / 103 g.

mm (inch)

**N-2855
Aluminum Carabiner**

Aluminum alloy, SAE 7075

Art. No.	Gate Feature		
	Screw Gate	Twist Locking	Triple Locking
N-2855		✓	
N-2855-TR			✓

Anodized Net weight : 4.6 oz. / 132 g.

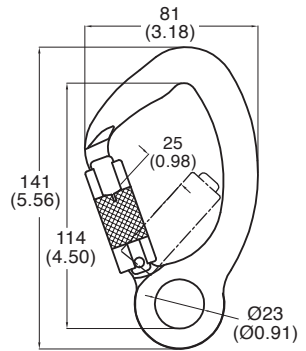

mm (inch)

**N-2857
Aluminum Indicator Swivel Carabiner**

Aluminum alloy, SAE 7075

Art. No.	Gate Feature		
	Screw Gate	Twist Locking	Triple Locking
N-2857		✓	
N-2857-TR			✓

Anodized Net weight : 6.2 oz. / 177 g.

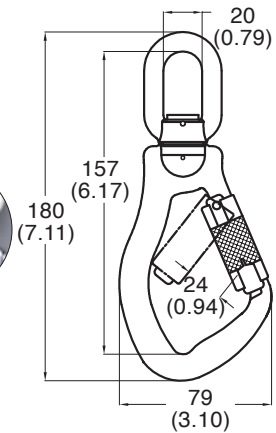

Indicator activation

mm (inch)

**N-2857 / 0
Aluminum Swivel Carabiner**

Aluminum alloy, SAE 7075

Art. No.	Gate Feature		
	Screw Gate	Twist Locking	Triple Locking
N-2857 / 0-0	✓		
N-2857 / 0-TR			✓

Anodized Net weight : 6.1 oz. / 172 g.

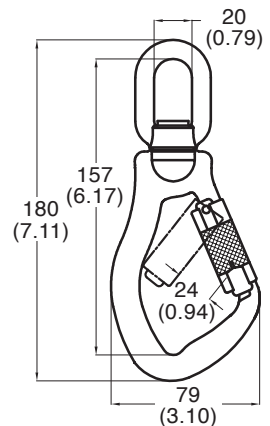

mm (inch)

YOKE Aluminum carabiners are tested by :

Min. Breaking load : 5000 lbs / 23 kN
Meets EN 362:2004



N-2859
Aluminum Carabiner

Aluminum alloy, SAE 7075





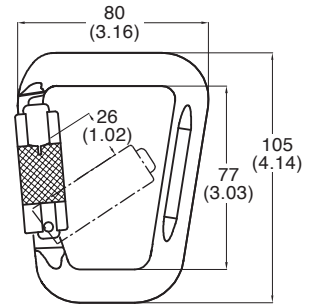





Art. No.	Gate Feature			Body
	Screw Gate	Twist Locking	Triple Locking	Captive Pin
N-2859-0	✓			
N-2859		✓		
N-2859-TR			✓	
N-2859-CP		✓		✓
N-2859-TRCP			✓	✓

Anodized Net weight : 4.1 oz. / 118 g.













mm (inch)

Aluminum Carabiner

										
Art. NO.	N-281	N-2859	N-270	N-282	N-272	N-273	N-276	N-271	N-283	N-2854
Ø mm (inch)	10 (0.39)	--	11 (0.43)	11 (0.43)	12 (0.47)	--	--	12 (0.47)	12 (0.47)	--
Breaking load minimum (kN)	23 (kN)	23 (kN)	23 (kN)	23 (kN)	23 (kN)	30 (kN)	24 (kN)	25 (kN)	23 (kN)	25 (kN)
Gate opening mm (inch)	20 (0.79)	26 (1.02)	19 (0.75)	18 (0.71)	23 (0.91)	22 (0.87)	23 (0.91)	22 (0.87)	22 (0.87)	27 (1.06)
O.L. mm (inch)	104 (4.09)	105 (4.13)	109 (4.29)	110 (4.33)	112 (4.41)	112 (4.41)	112 (4.41)	113 (4.45)	113 (4.45)	122 (4.80)

Aluminum Carabiner

											
Art. NO.	N-274	N-2852	N-284	N-275	N-2855	N-2750	N-2857	N-2857 / 0	N-287	N-277	N-278
Ø mm (inch)	12 (0.47)	--	11 (0.43)	--	--	--	--	--	15 (0.59)	16 (0.63)	16 (0.63)
Breaking load minimum (kN)	25 (kN)	23 (kN)	23 (kN)	28 (kN)	30 (kN)	23 (kN)	30 (kN)	30 (kN)	23 (kN)	35 (kN)	23 (kN)
Gate opening mm (inch)	23 (0.91)	25 (0.98)	25 (0.98)	20 (0.79)	25 (0.98)	22 (0.87)	24 (0.94)	24 (0.94)	42 (1.64)	52 (2.05)	52 (2.05)
O.L. mm (inch)	124 (4.88)	124 (4.88)	125 (4.92)	134 (5.28)	141 (5.55)	176 (6.93)	180 (7.09)	180 (7.09)	185 (7.74)	225 (8.85)	239 (9.41)





100% proof loaded to 3600 lbs / 16 kN
Min. Breaking load : 5000 lbs / 23 kN
 Meets ANSI Z359.12-2019 CSA Z259.12-16 EN 362:2004

N-2852G

Aluminum Carabiner 3600 LBS gate strength

Aluminum alloy, SAE 7075

Art. No.	Gate Feature			Body
	3600Lbs Gate Strength	Twist Locking	Triple Locking	Captive Pin
N-2852G	✓	✓		
N-2852G-TR	✓		✓	
N-2852G-CP	✓	✓		✓
N-2852G-TRCP	✓		✓	✓

Anodized Net weight : 4.6 oz. / 131 g

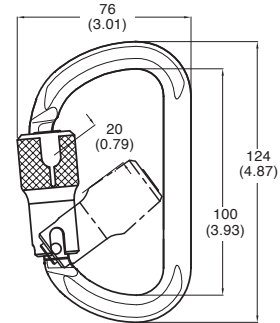

mm (inch)

N-2853G

Aluminum Carabiner 3600 LBS gate strength

Aluminum alloy, SAE 7075

Art. No.	Gate Feature			Body
	3600Lbs Gate Strength	Twist Locking	Triple Locking	Captive Pin
N-2853G	✓	✓		
N-2853G-TR	✓		✓	
N-2853G-CP	✓	✓		✓
N-2853G-TRCP	✓		✓	✓

Anodized Net weight : 5.3 oz. / 149.1 g

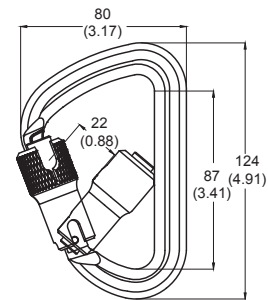

mm (inch)

N-2854G

Aluminum Carabiner 3600 LBS gate strength

Aluminum alloy, SAE 7075

Art. No.	Gate Feature			Body
	3600Lbs Gate Strength	Twist Locking	Triple Locking	Captive Pin
N-2854G	✓	✓		
N-2854G-TR	✓		✓	
N-2854G-CP	✓	✓		✓
N-2854G-TRCP	✓		✓	✓

Anodized Net weight : 4.37 oz. / 124 g

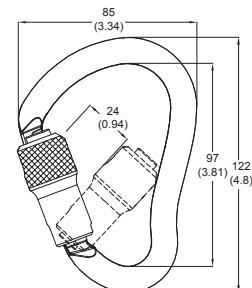

mm (inch)

YOKE carabiners are tested by :

100% proof loaded to 3600 lbs / 16 kN
Min. Breaking load : 5000 lbs / 23 kN
Meets ANSI Z359.12-2019 CSA Z259.12-16 EN 362:2004



N-2855G

Aluminum Carabiner 3600 LBS gate strength

Aluminum alloy, SAE 7075

Art. No.	Gate Feature		
	3600Lbs Gate Strength	Twist Locking	Triple Locking
N-2855G	✓	✓	
N-2855G-TR	✓		✓

Anodized Net weight : 5.3 oz. / 149.1 g

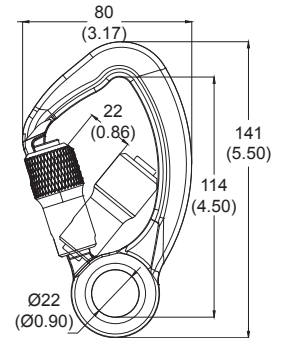

mm (inch)

N-2857G

Aluminum Indicator Swivel Carabiner

3600 LBS gate strength Aluminum alloy, SAE 7075

Art. No.	Gate Feature		
	3600Lbs Gate Strength	Twist Locking	Triple Locking
N-2857G	✓	✓	
N-2857G-TR	✓		✓

Anodized Net weight : 7.2 oz. / 205 g

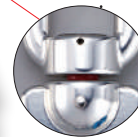

Indicator activation

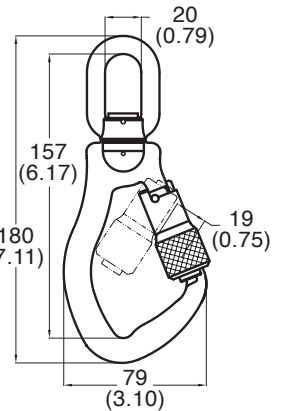

mm (inch)

N-2857 / OG

Aluminum Swivel Carabiner

3600 LBS gate strength Aluminum alloy, SAE 7075

Art. No.	Gate Feature		
	3600Lbs Gate Strength	Twist Locking	Triple Locking
N-2857 / OG	✓	✓	
N-2857 / OG-TR	✓		✓

Anodized Net weight : 7.0 oz. / 200 g

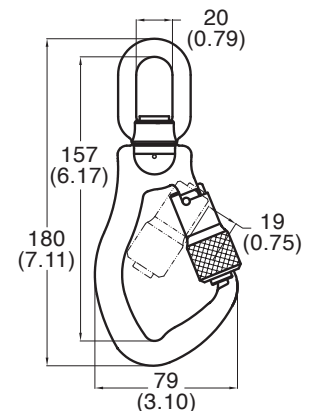

mm (inch)



100% proof loaded to 3600 lbs / 16 kN
Min. Breaking load : 5000 lbs / 23 kN
Meets ANSI Z359.12-2019 CSA Z259.12-16 EN 362:2004

N-2859G

Aluminum Carabiner 3600 LBS gate strength

Aluminum alloy, SAE 7075

Art. No.	Gate Feature			Body
	3600Lbs Gate Strength	Twist Locking	Triple Locking	Captive Pin
N-2859G	✓	✓		
N-2859G-TR	✓		✓	
N-2859G-CP	✓	✓		✓
N-2859G-TRCP	✓		✓	✓

Anodized Net weigh : 5.0 oz. / 142 g

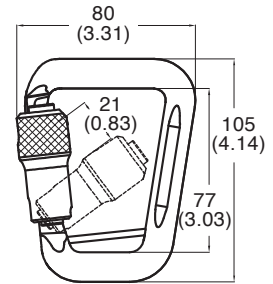

mm (inch)

N-2868G

Aluminum Carabiner 3600 LBS gate strength

Aluminum alloy, SAE 7075

Art. No.	Gate Feature			Body
	3600Lbs Gate Strength	Twist Locking	Triple Locking	Captive Pin
N-2868G-CP	✓	✓		✓
N-2868G-TRCP	✓		✓	✓

N-2868GL-CP

**Specially designed for left-handed friendly.*

Anodized Net weight : 15.9 oz. / 450 g

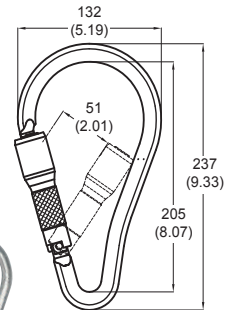

N-2868GL-CP

mm (inch)

SNAG FREE Aluminum Carabiner



Art.NO.	N-2859G	N-2854G	N-2852G	N-2853G	N-2855G	N-2857G	N-2868G
Breaking load minimum(kN)	23 kN	25 kN	23 kN	40 kN	30 kN	30 kN	25 kN
Gate opening mm(inch)	21 (0.83)	24 (0.94)	20 (0.79)	22 (0.87)	22 (0.87)	19 (0.75)	51 (2.01)
O.L mm(inch)	105 (4.13)	122 (4.80)	124 (4.88)	124 (4.88)	141 (5.55)	180 (7.09)	237 (9.33)





This fall arrester is to be used as **only as a component** in a work positioning or fall arrest system. As part of this system, the fall arrester must be tested prior to distribution to the end user, with all other components in the system including - but not limited to - lifeline, energy absorber, connecting hardware, fall protection harness, etc. This testing must be in compliance with and conducted in accordance to ANSI, OSHA, CSA, and any other applicable standard(s). It is the system manufacturer's responsibility to ensure the compatibility of this fall arrester with the system and to provide applicable instructions to end user. These instructions must detail proper use of the fall arrester, including correct orientation (UP position), as well as how to safely adjust the position of the fall arrester on the lifeline.

N-610
Fall Arrester
(Open type)

Stainless steel
For Rope : 16 mm (5 / 8 ")
Min. Breaking load : 3600 lbs / 16 kN
Meets :
● ANSI Z359.1
● EN 353-2
Net weight : 20.2 oz. / 572 g

Polished



Open for attachment

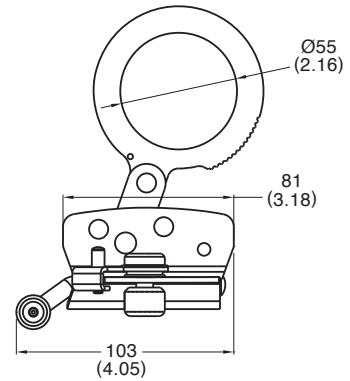

mm (inch)

N-610LY
Fall Arrester with integral lanyard

Stainless steel
For Rope : 16 mm (5 / 8 ")
Max elongation : 61 in (156 cm)
Max arresting force : 1300 lbs (6 kN)
Max freefall : 3.28 ft (1 m)
Worker mass range : 100-350 lbs (45-160 kgs)
Min. Breaking load : 3600 lbs / 16 kN
Meets :
● CSA Z259.2.5-17
● ANSI Z359.15-14
Net weight : 42.28 oz. / 1208g

Polished



mm (inch)

N-630
Fall Arrester
(Open type)

Steel
For Rope : 16 mm (5 / 8 ")
Min. Breaking load : 3600 lbs / 16 kN
Meets :
● ANSI Z359.1
● EN 353-2
Net weigh : 20.2 oz. / 572 g

Zinc Plated

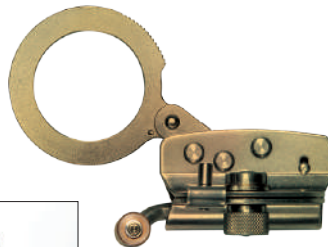

Open for attachment

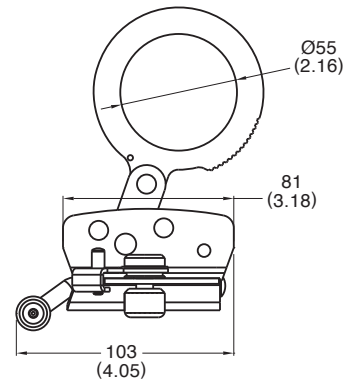

mm (inch)

N-630LY
Fall Arrester with integral lanyard

Steel
For Rope : 16 mm (5 / 8 ")
Max elongation : 61 in (156 cm)
Max arresting force : 1300 lbs (6 kN)
Max freefall : 3.28 ft (1 m)
Worker mass range : 100-350 lbs (45-160 kgs)
Min. Breaking load : 3600 lbs / 16 kN
Meets :
● CSA Z259.2.5-17
● ANSI Z359.15-14
Net weight : 42.67 oz. / 1208 g

Zinc Plated



mm (inch)

This fall arrester is to be used as **only as a component** in a work positioning or fall arrest system. As part of this system, the fall arrester must be tested prior to distribution to the end user, with all other components in the system including - but not limited to - lifeline, energy absorber, connecting hardware, fall protection harness, etc. This testing must be in compliance with and conducted in accordance to ANSI, OSHA, CSA, and any other applicable standard(s). It is the system manufacturer's responsibility to ensure the compatibility of this fall arrester with the system and to provide applicable instructions to end user. These instructions must detail proper use of the fall arrester, including correct orientation (UP position), as well as how to safely adjust the position of the fall arrester on the lifeline.



N-616
Fall Arrester
(Open type)

Stainless steel

For Rope : 12.7 – 14 mm (1 / 2 " - 9 / 16 ")

Min. Breaking load : 3600 lbs / 16 kN

Meets :

- ANSI Z359.1
- EN 353-2

Net weight : 20.2 oz. / 572 g

Polished



Open for attachment

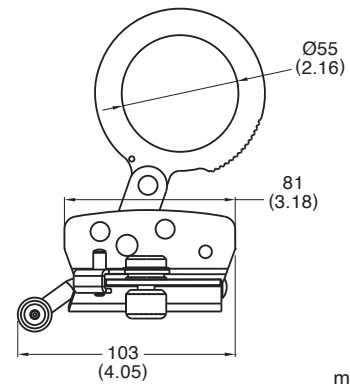

mm (inch)

N-636
Fall Arrester
(Open type)

Steel

For Rope : 12.7 - 14 mm (1 / 2 " - 9 / 16 ")

Min. Breaking load : 3600 lbs / 16 kN

Meets :

- ANSI Z359.1
- EN 353-2

Net weight : 20.8 oz. / 589 g

Zinc Plated

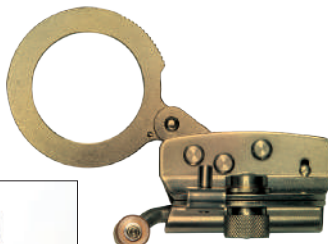

Open for attachment

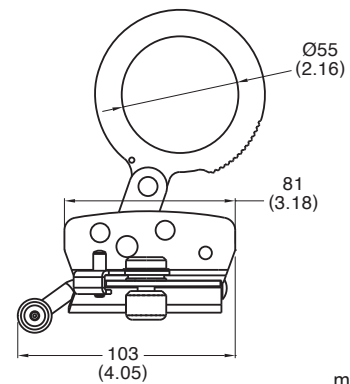

mm (inch)

N-617
Fall Arrester
(Open type)

Stainless steel

For Rope : 14 - 16 mm (9 / 16 " - 5 / 8 ")

Min. Breaking load : 3600 lbs / 16 kN

Meets :

- ANSI Z359.1
- EN 353-2

Net weight : 15.1 oz. / 428 g

Polished



Open for attachment

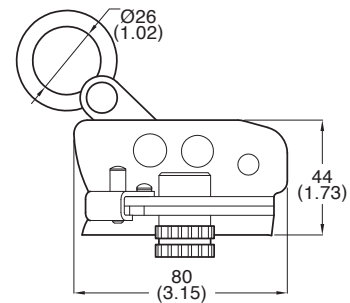

mm (inch)

N-637
Fall Arrester
(Open type)

Steel

For Rope : 14 - 16 mm (9 / 16 " - 5 / 8 ")

Min. Breaking load : 3600 lbs / 16 kN

Meets :

- ANSI Z359.1
- EN 353-2

Net weight : 15.1 oz. / 428 g

Zinc Plated

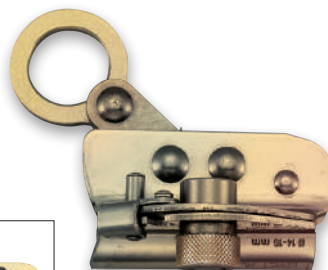

Open for attachment

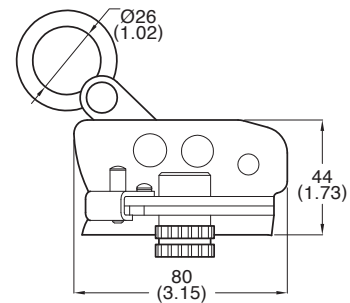

mm (inch)



This fall arrester is to be used as **only as a component** in a work positioning or fall arrest system. As part of this system, the fall arrester must be tested prior to distribution to the end user, with all other components in the system including - but not limited to - lifeline, energy absorber, connecting hardware, fall protection harness, etc. This testing must be in compliance with and conducted in accordance to ANSI, OSHA, CSA, and any other applicable standard(s). It is the system manufacturer's responsibility to ensure the compatibility of this fall arrester with the system and to provide applicable instructions to end user. These instructions must detail proper use of the fall arrester, including correct orientation (UP position), as well as how to safely adjust the position of the fall arrester on the lifeline.

N-618
Fall Arrester
(Open type)

Stainless steel
For Rope : 12.7 - 14 mm (1 / 2 " - 9 / 16 ")
Min. Breaking load : 3600 lbs / 16 kN
Meets :
● ANSI Z359.1
● EN 353-2
Net weight : 20.3 oz. / 580 g

Polished

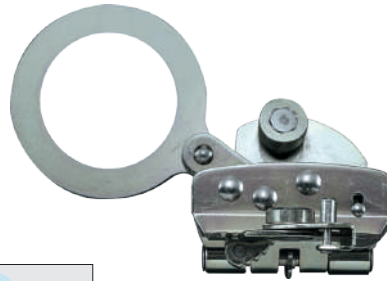
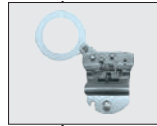

Open for attachment

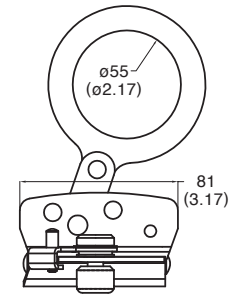

mm (inch)

N-638
Fall Arrester
(Open type)

Steel
For Rope : 12.7 - 14 mm (1 / 2 " - 9 / 16 ")
Min. Breaking load : 3600 lbs / 16 kN
Meets :
● ANSI Z359.1
● EN 353-2
Net weight : 20.5 oz. / 586 g

Zinc Plated

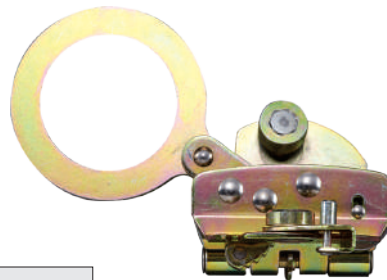
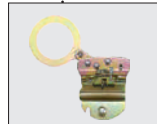

Open for attachment

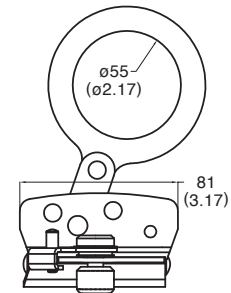

mm (inch)

N-619T
Fall Arrester With Parking Feature
(Open type)

Stainless Steel
For Rope : 12.7 - 14 mm (1 / 2 " - 9 / 16 ")
Min. Breaking load : 3600 lbs / 16 kN
Meets :
● ANSI Z359.1
● EN 353-2
Net weight : 17.5 oz. / 499 g

Polished

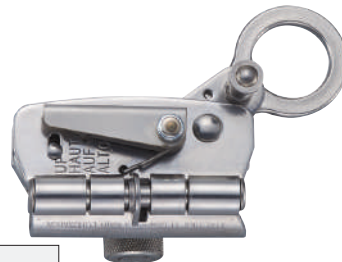

Open for attachment

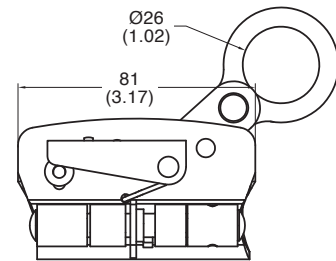

mm (inch)

N-619
Fall Arrester
(Open type)

Stainless Steel
For Rope : 12.7 - 14 mm (1 / 2 " - 9 / 16 ")
Min. Breaking load : 3600 lbs / 16 kN
Meets :
● ANSI Z359.1
● EN 353-2
Net weight : 14.9 oz. / 428 g

Polished

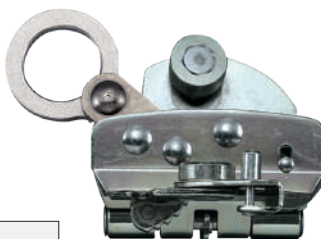

Open for attachment

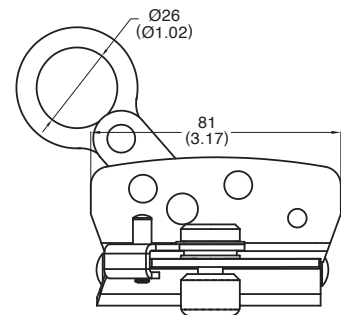

mm (inch)

This fall arrester is to be used as **only as a component** in a work positioning or fall arrest system. As part of this system, the fall arrester must be tested prior to distribution to the end user, with all other components in the system including - but not limited to - lifeline, energy absorber, connecting hardware, fall protection harness, etc. This testing must be in compliance with and conducted in accordance to ANSI, OSHA, CSA, and any other applicable standard(s). It is the system manufacturer's responsibility to ensure the compatibility of this fall arrester with the system and to provide applicable instructions to end user. These instructions must detail proper use of the fall arrester, including correct orientation (UP position), as well as how to safely adjust the position of the fall arrester on the lifeline.



N-639
Fall Arrester
(Open type)

Steel

For Rope : 12.7 - 14 mm (1 / 2 " - 9 / 16 ")

Min. Breaking load : 3600 lbs / 16 kN

Meets :

- ANSI Z359.1
- EN 353-2

Net weight : 15.1 oz. / 428 g

Zinc Plated

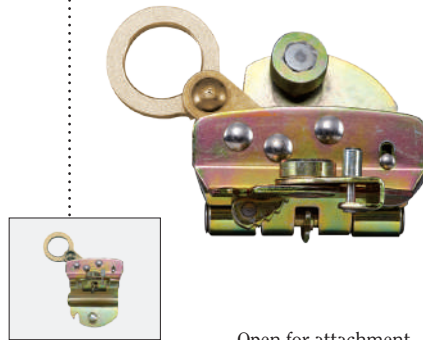

Open for attachment

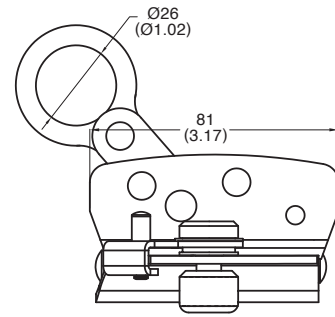

mm (inch)

N-606AP
Fall Arrester-Positioning

Stainless steel

For Rope : 16 mm (5/8")

Min. Breaking load : 3600 lbs / 16 kN

Meets:

- ANSI Z359.1
- EN 353-2

Net weight : 25.9 oz. / 733 g

Polished



Open for attachment

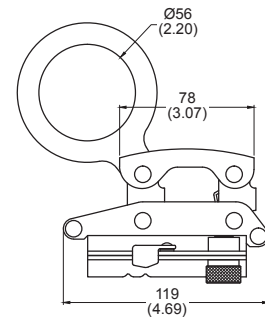

mm (inch)

N-602-12
Fall Arrester with Eye

Steel

For Rope : 12 mm (1 / 2 ")

Min. Breaking load : 3600 lbs / 16 kN

Meets :

- ANSI Z359.1
- EN 358

Net weight : 14.4 oz. / 441 g

Zinc Plated

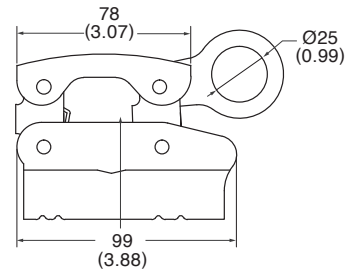

mm (inch)

N-602
Fall Arrester with Eye

Steel

For Rope : 16 mm (5 / 8 ")

Min. Breaking load : 3600 lbs / 16 kN

Meets :

- EN 353-2

Net weight : 16.2 oz. / 458 g

Zinc Plated

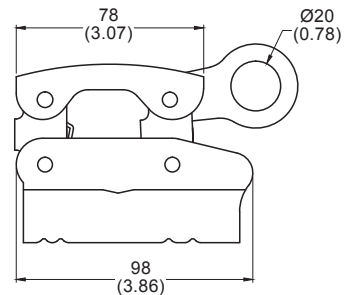

mm (inch)



This fall arrester is to be used as **only as a component** in a work positioning or fall arrest system. As part of this system, the fall arrester must be tested prior to distribution to the end user, with all other components in the system including - but not limited to - lifeline, energy absorber, connecting hardware, fall protection harness, etc. This testing must be in compliance with and conducted in accordance to ANSI, OSHA, CSA, and any other applicable standard(s). It is the system manufacturer's responsibility to ensure the compatibility of this fall arrester with the system and to provide applicable instructions to end user. These instructions must detail proper use of the fall arrester, including correct orientation (UP position), as well as how to safely adjust the position of the fall arrester on the lifeline.

N-668 Fall Arrester

Aluminum alloy
 Rope size : 11-13 mm
 Certified with 11mm rope
 Meets:
 ● EN353-2
 ● EN358
 Net weight : 5.6 oz. / 159 g

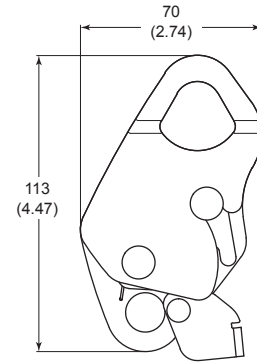

mm (inch)

Anodized

N-626 Vertiguard-Fall Arrester

Stainless steel, Aluminum
 Wire Rope : 10mm (3/8")
 Min. Breaking load : 5000 lbs / 23 kN
 Meets :
 ● ANSI Z359.16
 Net weight : 32 oz. / 910 g

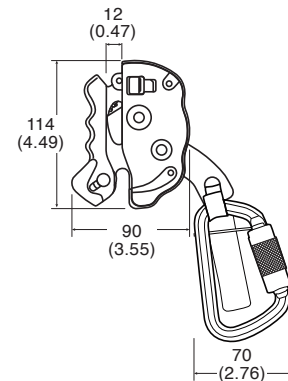

mm (inch)

Anodized

New

N-620/N-622 Cable Fall Arrester With Eye

Stainless steel
 Min. Breaking load : 3600 lbs / 16 kN
 Meets :
 ● EN 353-2

Art No.	Wire Rope	Net Weight
N-620	8mm(5/16")	16.4 oz./465g
N-622	10mm(3/8")	16.9oz./478g

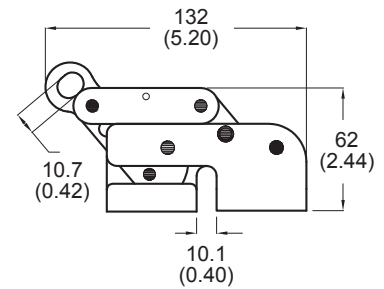

mm (inch)

Polished

N-621/N-623 Cable Fall Arrester With Eye

Stainless steel
 Min. Breaking load : 3600 lbs / 16 kN
 Meets :
 ● ANSI Z359.1
 ● EN 353-2

Art No.	Wire Rope	Net Weight
N-621	8mm(5/16")	16.8 oz./477g
N-623	10mm(3/8")	17.3oz./490g



Anti-upside down

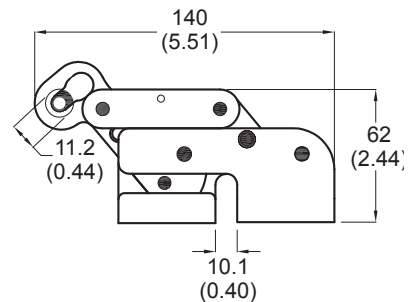

mm (inch)

Polished

This fall arrester is to be used as **only as a component** in a work positioning or fall arrest system. As part of this system, the fall arrester must be tested prior to distribution to the end user, with all other components in the system including - but not limited to - lifeline, energy absorber, connecting hardware, fall protection harness, etc. This testing must be in compliance with and conducted in accordance to ANSI, OSHA, CSA, and any other applicable standard(s). It is the system manufacturer's responsibility to ensure the compatibility of this fall arrester with the system and to provide applicable instructions to end user. These instructions must detail proper use of the fall arrester, including correct orientation (UP position), as well as how to safely adjust the position of the fall arrester on the lifeline.



N-604
Fall Arrester with Hook

Steel
 For Rope : 16 mm (5 / 8 ")
 Min. Breaking load : 3600 lbs / 16 kN
 Meets :
 ● EN 353-2
 Net weight : 19.3 oz. / 547 g

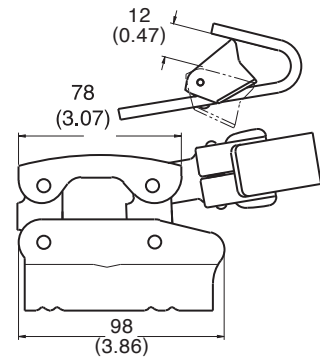

mm (inch)

Zinc Plated

N-650
Fall Arrester With Fixed Cam

Aluminum alloy
 Rope size : Ø 9 mm — Ø 13 mm
 Net weight : 5.8 oz. / 166 g

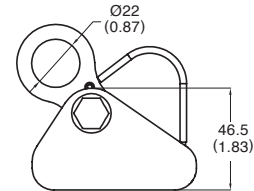

mm (inch)

Anodized

N-650B
Fall Arrester With Removable Cam

Aluminum alloy
 Rope size : Ø 9 mm — Ø 13 mm
 Net weight : 6.2 oz. / 177 g

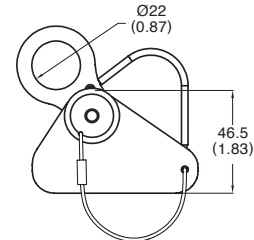

mm (inch)

Anodized

N-651
Rope Adjuster Grab With Fixed Cam

Aluminum alloy
 Rope size : Ø 9 mm — Ø 13 mm
 Net weight : 6.1 oz. / 173 g
 Not for fall arrest

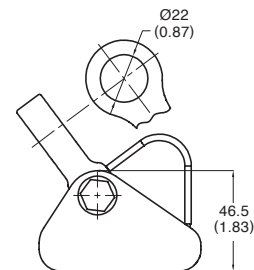

mm (inch)

Anodized



This fall arrester is to be used as **only as a component** in a work positioning or fall arrest system. As part of this system, the fall arrester must be tested prior to distribution to the end user, with all other components in the system including - but not limited to - lifeline, energy absorber, connecting hardware, fall protection harness, etc. This testing must be in compliance with and conducted in accordance to ANSI, OSHA, CSA, and any other applicable standard(s). It is the system manufacturer's responsibility to ensure the compatibility of this fall arrester with the system and to provide applicable instructions to end user. These instructions must detail proper use of the fall arrester, including correct orientation (UP position), as well as how to safely adjust the position of the fall arrester on the lifeline.

N-652
Rope Adjuster Grab With
Fixed Cam

Aluminum alloy
 Rope size : Ø 9 mm — Ø 13 mm
 Net weight : 6.1 oz. / 173 g
 Not for fall arrest

New

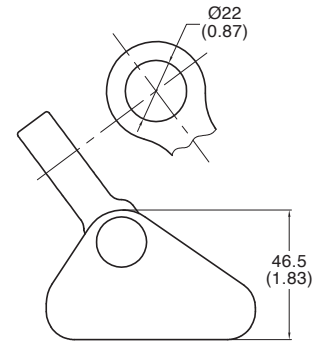

mm (inch)

Anodized

N-651B
Rope Adjuster Grab With
Removable Cam

Aluminum alloy
 Rope size : Ø 9 mm — Ø 13 mm
 Net weight : 6.4 oz. / 182 g
 Not for fall arrest

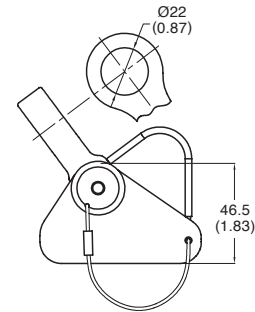

mm (inch)

Anodized

N-670
Positioning Grab

Stainless steel / Aluminum alloy
 Rope size : Ø 14 mm — Ø 16 mm
 Net weight : 8.3 oz. / 238 g

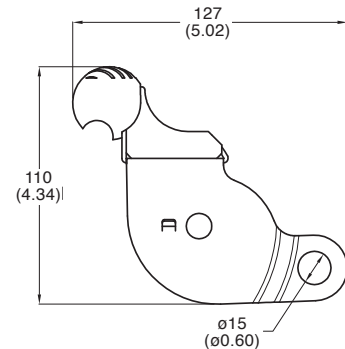

mm (inch)

Polished

N-660
Fall Arrester

Aluminum alloy
 Rope size : Ø 12 mm
 Net weight : 7.4 oz. / 210 g

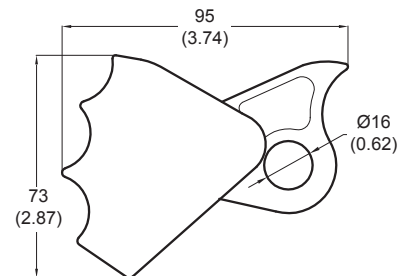

mm (inch)

Anodized

N-660-16
 Rope size : Ø 16 mm

This fall arrester is to be used as **only as a component** in a work positioning or fall arrest system. As part of this system, the fall arrester must be tested prior to distribution to the end user, with all other components in the system including - but not limited to - lifeline, energy absorber, connecting hardware, fall protection harness, etc. This testing must be in compliance with and conducted in accordance to ANSI, OSHA, CSA, and any other applicable standard(s). It is the system manufacturer's responsibility to ensure the compatibility of this fall arrester with the system and to provide applicable instructions to end user. These instructions must detail proper use of the fall arrester, including correct orientation (UP position), as well as how to safely adjust the position of the fall arrester on the lifeline.



N-608
N-609
Rope Tensioner

Steel, heat treated
 Rope Size : 16 mm (5 / 8 ")
 Net weight : 58.6 oz. / 1.66 kg

X length	N-608	N-609
	17.1mm	15.2mm
	0.67 inches	0.60 inches

Zinc Plated

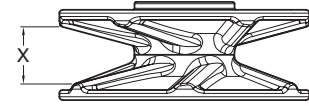
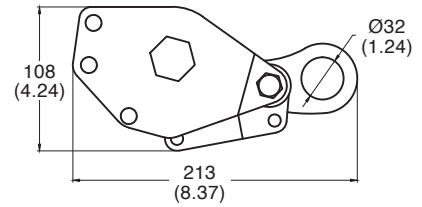
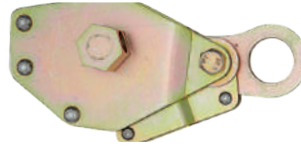

mm (inch)

N-608AL
Aluminum Rope Tensioner

Sheet aluminum alloy
 Rope Size : 16 mm (5 / 8 ")
 Net weight : 37.4 oz. / 1.06 kg

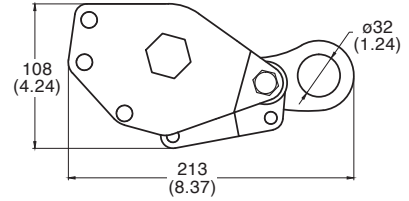
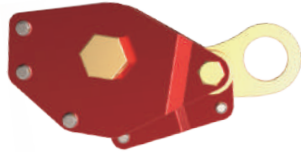

Anodized

mm (inch)



N-86050
Removable Concrete Anchor

Stainless Steel
 Hole Diameter : 20 mm
 Min. Breaking load : 5000 lbs / 23 kN
 Meets :
 ● ANSI Z359.18-2017
 Net weight : 10.3 oz. / 291 g

PATENT PENDING

Polished

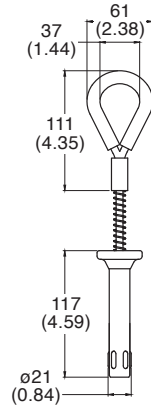

mm (inch)

N-8611
Toggle Lok Bolt Anchor

Stainless Steel
 Hole Diameter:20mm
 Min. Breaking load : 5000 lbs / 23 kN
 Meets:
 ● ANSI Z259.18-2017
 Net weight : 7.3 oz. / 207 g

PATENT PENDING

Polished

New

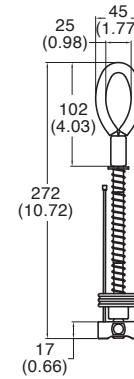

mm (inch)

N-800
Beam Anchor

Forged aluminum alloy
 For Beam : 101.6-330.2 mm (4"-13")
 Min. Breaking load : 5000 lbs / 23 kN
 Meets :
 ● ANSI Z359.18-2017
 Net weight : 71.6 oz. / 2.03 kg

Patent US 11286968

Anodized

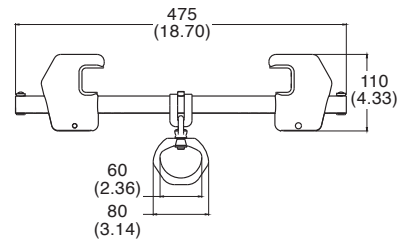

mm (inch)

N-5077
Wood Truss/Attic anchor

Min. Breaking load at 0° : 3000 lbs/13kN
 Min. Breaking load at 90° : 2000lbs/9 kN
 Max capacity : 1 User (310 lbs/140kg)
 Net weight : 11.8 / 335 g

Zinc Plated

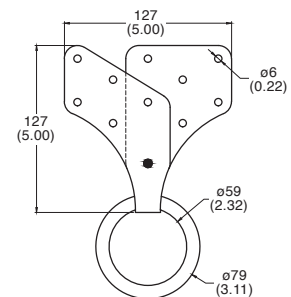

mm (inch)

**N-908
Roof Ring Anchor**

Steel, heat treated
Net weight : 34.71 oz. / 984 g

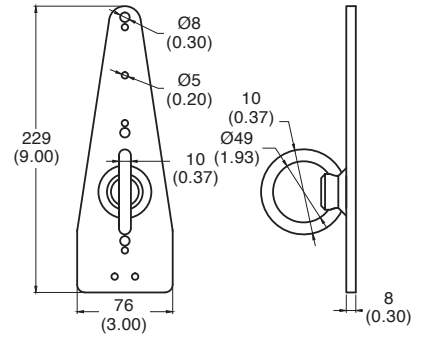

mm (inch)

Zinc Plated

**N-2817
D Ring with Bracket Weldment**

Sheet steel, heat treated
Min. Breaking load : 5000 lbs / 23 kN
Meets:
● ANZI Z359.18-2017
Net weight : 9.5 oz. / 268 g

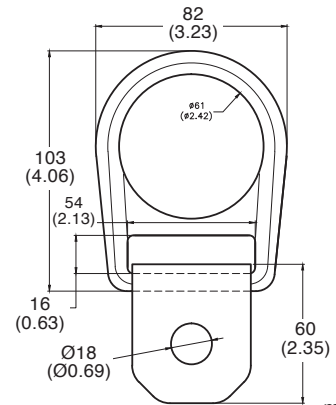

mm (inch)

yellow zinc

N-8232050B
Steel Swivel Anchor Base 5K

Forged steel, heat treated
 Min. Breaking load : 5000 lbs / 23 kN
 Meets :
 ● ANSI Z359.18-2017
 Net weight : 7.9 oz. / 225 g

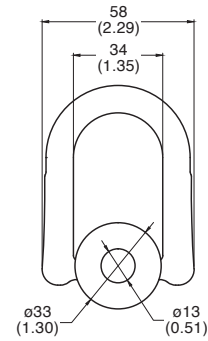

Yellow zinc

mm (inch)

N-8232100B
Steel Swivel Anchor Base 10K

Forged steel, heat treated
 Min. Breaking load : 10000 lbs / 45 kN
 Meets :
 ● ANSI Z359.18-2017
 Net weight : 28.4 oz. / 804 g

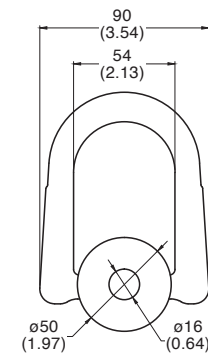

Yellow zinc

mm (inch)

N-8232050A
Steel Swivel Anchor w/ Bolt 5K

Forged steel, heat treated
 Min. Breaking load : 5000 lbs / 23 kN
 Meets :
 ● ANSI Z359.18-2017
 Net weight : 12.2 oz. / 346 g

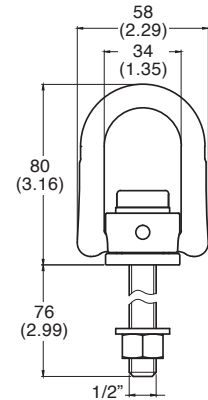

Yellow zinc

mm (inch)

N-8232100A
Steel Swivel Anchor w/ Bolt 10K

Forged steel, heat treated
 Min. Breaking load : 10000 lbs / 45 kN
 Meets :
 ● ANSI Z359.18-2017
 Net weight : 36.3 oz. / 1.03 kg

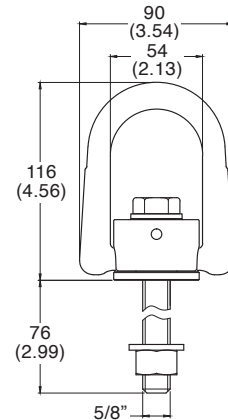

Yellow zinc

mm (inch)

**N-8232050W
Steel Swivel Anchor & Puck
Assembly 5K**

Forged steel, heat treated
 Min. Breaking load : 5000 lbs / 23 kN
 Meets :
 ● ANSI Z359.18-2017
 Net weight : 43.0 oz. / 1.22 kg

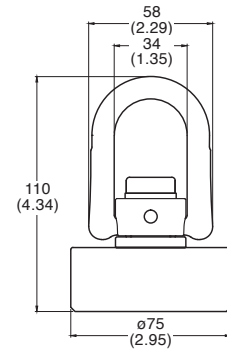

mm (inch)

Yellow zinc

**N-8232100W
Steel Swivel Anchor & Puck
Assembly 10K**

Forged steel, heat treated
 Min. Breaking load : 10000 lbs / 45 kN
 Meets :
 ● ANSI Z359.18-2017
 Net weight : 65.3 oz. / 1.85 kg

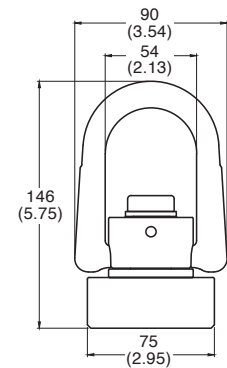

mm (inch)

Yellow zinc

Puck & Bolt

Steel

Part no.	N-8232050WA	N-8232100WA
Hole Diameter (A)	1/2"	5/8"
Net weight	33.4 oz./946 g	32.8 oz./930 g

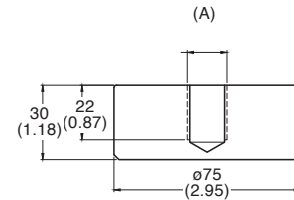
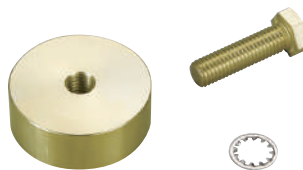

mm (inch)

Yellow zinc

**N-8232100TB
Back Plate**

Sheet steel
 Net weight : 26.6 oz. / 755 g

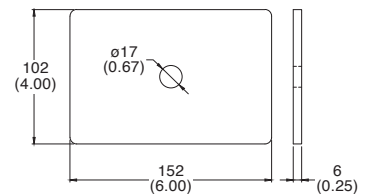
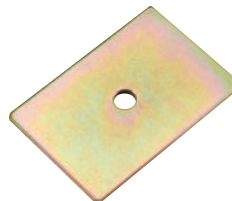

mm (inch)

Yellow zinc

N-8S232050B
stainless steel Swivel Anchor
Base 5K

Stainless steel, heat treated
 Min. Breaking load: 5000 lbs / 23 kN
 Meets :
 ● ANSI Z359.18-2017
 Net weight : 28.50 oz. / 808 g

New

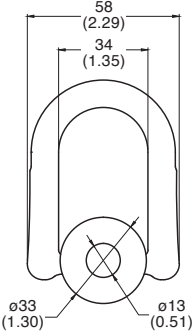

Polished

mm (inch)

N-8S232050A
stainless steel Swivel Anchor w/
Bolt 5K

Stainless steel, heat treated
 Min. Breaking load: 5000 lbs / 23 kN
 Meets :
 ● ANSI Z359.18-2017
 Net weight : 37.39 oz. / 1,060 g

New

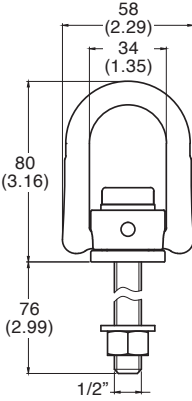

Polished

mm (inch)

N-8S232050WA
Stainless steel Puck & Bolt

Stainless steel, heat treated
 Net weight : 37.46 oz. / 1,062 g

New

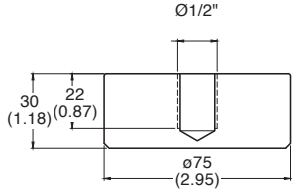
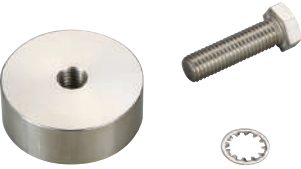

Polished

mm (inch)

**N-903
Anchorage Connector (1 / 2")**

Forged steel, heat treated
 100% proof loaded to 3600 lbs / 16 kN
 Min. Breaking load : 5000 lbs / 23 kN
 for 1 / 2 : (M13) bolt.
 Net weight : 21.2 oz. / 600 g

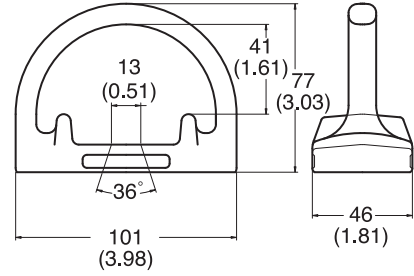

Zinc Plated

"Warning: Bolts for anchorage connector installation to be minimum grade 8 quality with lock washer."

mm (inch)

**N-904
Anchorage Connector (5 / 8")**

Forged steel, heat treated
 100% proof loaded to 3600 lbs / 16 kN
 Min. Breaking load : 5000 lbs / 23 kN
 for 5 / 8 : (M16) bolt.
 Net weight : 21.3 oz. / 582 g

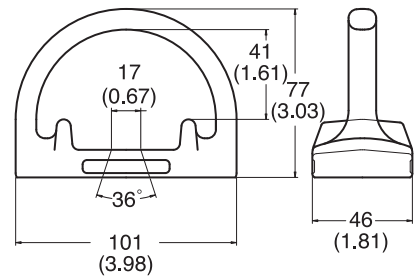

Zinc Plated

"Warning: Bolts for anchorage connector installation to be minimum grade 8 quality with lock washer."

mm (inch)

**N-905
Anchorage Connector (3 / 4")**

Forged steel, heat treated
 100% proof loaded to 3600 lbs / 16 kN
 Min. Breaking load : 5000 lbs / 23 kN
 for 3 / 4 : (M19) bolt.
 Net weight : 19.6 oz. / 563 g

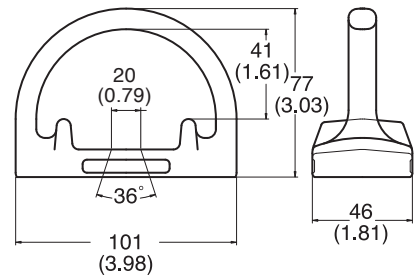

Zinc Plated

"Warning: Bolts for anchorage connector installation to be minimum grade 8 quality with lock washer."

mm (inch)

**N-907
Anchorage Connector**

Completed with grade 8 nut & lock washer
 Forged steel, heat treated
 100% proof loaded to 3600 lbs / 16 kN
 Min. Breaking load : 5000 lbs / 23 kN
 Net weight : 21.3 oz. / 604 g

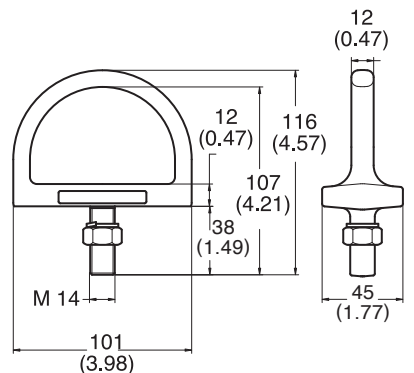

Zinc Plated

mm (inch)

**N-481
N-481R
Roof Anchor-reusable**

Net weight : 39.1 oz. / 1108 g

Art. No.	Color
N-481	Zinc plated
N-481R	Red Powder Coated

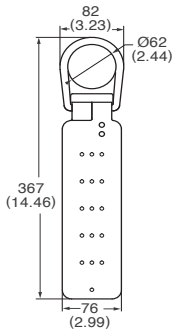

mm (inch)

**N-485
Swivel Roof Anchor Bracket**

Net weight : 39.2 oz. / 1120 g

Patent US 9744387

Zinc Plated

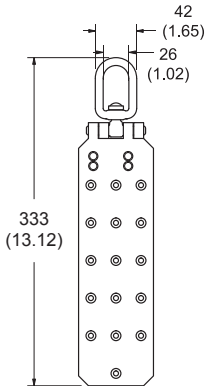

mm (inch)

**N-5072R
Roof Anchor Bracket**

Net weight : 39.5 oz. / 1120 g

Red Powder Coated

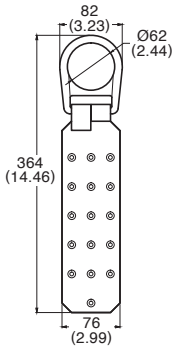

mm (inch)

**N-5072F
Roof Anchor Bracket**

Net weight : 39.5 oz. / 1120 g

Zinc Plated

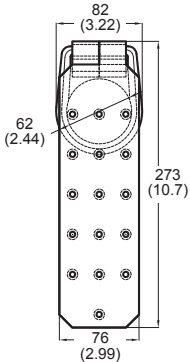
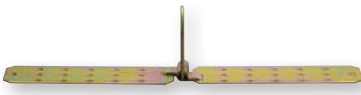

For Flat Surface mm (inch)

**N-480
Roof Anchor-disposable**

Net weight : 12.6 oz. / 357 g



Zinc Plated

**N-4805
Roof Anchor**

Net weight : 12.5 oz. / 335 g

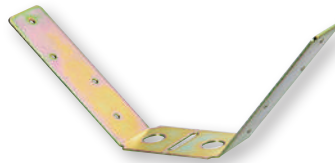

Zinc Plated

For Flat Surface

**N-350 / N-3501 / N-3502
Anchorage Connector**

Stainless steel, SUS 304
Min. Breaking load : 5000 lbs / 23 kN
Net weight : 12.9 oz. / 366 g

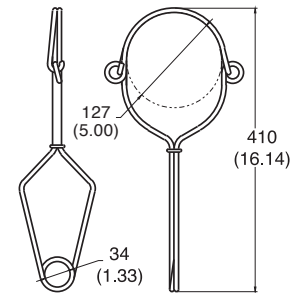
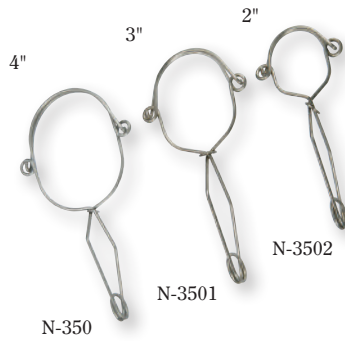

Polished

mm (inch)

**N-459
Steel Plate**

Net weight : 9.5 oz. / 271 g

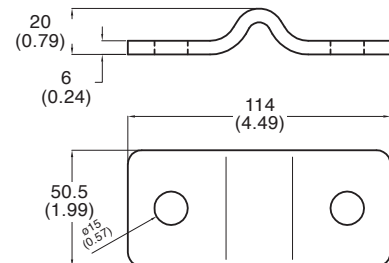
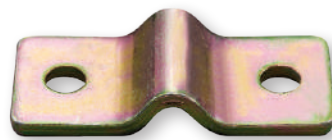

Zinc Plated

mm (inch)

N-351
Swivels - Eye to Eye
(non-indicator)

Forged steel, heat treated
 100% proof loaded to 3600 lbs / 16 kN
 Min. Breaking load : 5000 lbs / 23 kN
 Net weight : 6.2 oz. / 176 g

N-3035M
Swivel Eye

Forged steel, heat treated
 Net weight : 2.5 oz. / 72 g

Zinc Plated



N-3035M

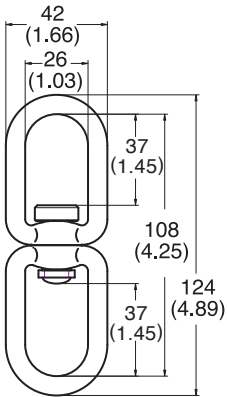

mm (inch)

N-352
Swivels - Jaw to Jaw
(non-indicator)

Forged steel, heat treated
 100% proof loaded to 3600 lbs / 16 kN
 Min. Breaking load : 5000 lbs / 23 kN
 Net weight : 6.3 oz. / 180 g

Zinc Plated

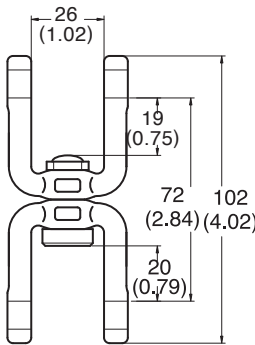

mm (inch)

N-353
Swivels - Jaw to Eye
(non-indicator)

Forged steel, heat treated
 100% proof loaded to 3600 lbs / 16 kN
 Min. Breaking load : 5000 lbs / 23 kN
 Net weight : 6.2 oz. / 175 g

Zinc Plated

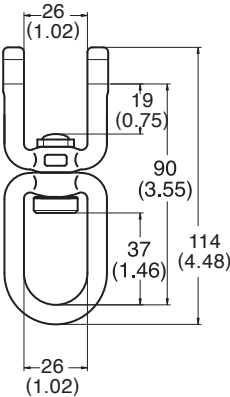

mm (inch)

N-354
Swivels - Eye to Eye
(non-indicator)

Forged steel, heat treated
 100% proof loaded to 3600 lbs / 16 kN
 Min. Breaking load : 5000 lbs / 23 kN
 Net weight : 7.1 oz. / 200 g

Zinc Plated

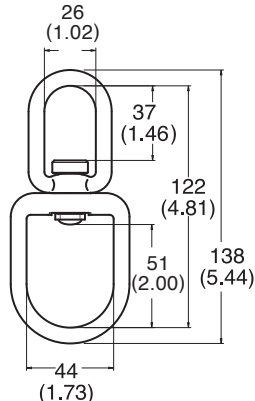

mm (inch)

**N-355
Indicator Swivels - Eye to Eye**

Forged steel, heat treated
 100% proof loaded to 3600 lbs / 16 kN
 Min. Breaking load : 5000 lbs / 23 kN
 Net weight : 7.4 oz. / 211 g

Zinc Plated



Indicator activation

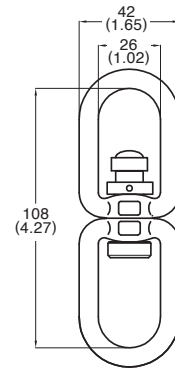

mm (inch)

**N-356
Indicator Swivels - Jaw to Jaw**

Forged steel, heat treated
 100% proof loaded to 3600 lbs / 16 kN
 Min. Breaking load : 5000 lbs / 23 kN
 Net weight : 6.7 oz. / 190 g

Zinc Plated



Indicator activation

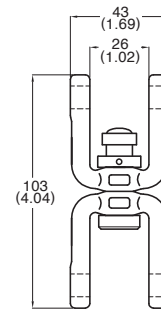

mm (inch)

**N-357
Indicator Swivels - Jaw to Eye**

Forged steel, heat treated
 100% proof loaded to 3600 lbs / 16 kN
 Min. Breaking load : 5000 lbs / 23 kN
 Net weight : 6.5 oz. / 185 g

Zinc Plated



Indicator activation

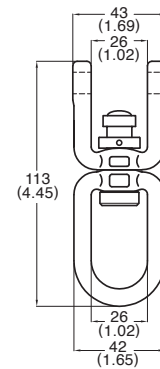

mm (inch)

**N-358
Indicator Swivels - Eye to Eye**

Forged steel, heat treated
 100% proof loaded to 3600 lbs / 16 kN
 Min. Breaking load : 5000 lbs / 23 kN
 Net weight : 7.4 oz. / 210 g

Zinc Plated



Indicator activation

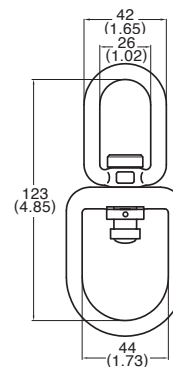

mm (inch)

N-3512
Swivel Eye Attachment

Steel, heat treated
Net weight : 8.82 oz. / 250 g

New

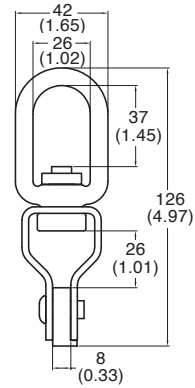

mm (inch)

Zinc plated

N-5372
Rescue Hauler Pulley-2 way
Auto Locking

Stamping aluminum alloy
Rope size : 11 mm
Working load limit : 250 kg
Net weight : 55.6 oz. / 1588 g

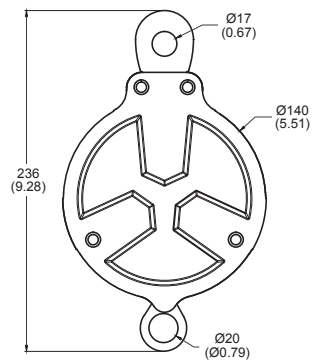

mm (inch)

Anodized

N-5331
Big Mobile Double Pulley

Stamping aluminum alloy
Rope size : Maximum to 13 mm
Min. Breaking load : 50 kN
Net weight : 18.9 oz. / 539 g

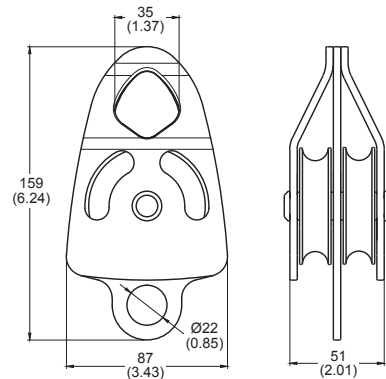

mm (inch)

Anodized

N-5331B
Big Mobile Double Pulley

* With Ball Bearing
* With Stainless Sheave
Stamping aluminum alloy
Rope size : Maximum to 13 mm
Min. Breaking load : 50 kN
Net weight : 29.4 oz. / 834 g

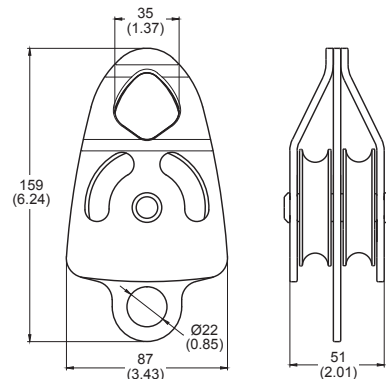

mm (inch)

Anodized

**N-6901
Cable Glider**

Stainless Steel
Net weight : 8.5 oz. / 241 g

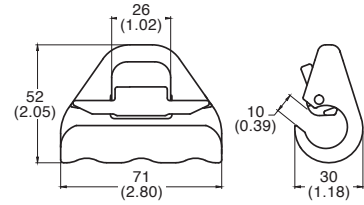

Polished

mm (inch)

**N-5340
Tyrolean Pulleys**

Stamping aluminum alloy
Rope size : Maximum to 13 mm
Min. Breaking load : 24 kN
Net weight : 8.6 oz. / 245 g

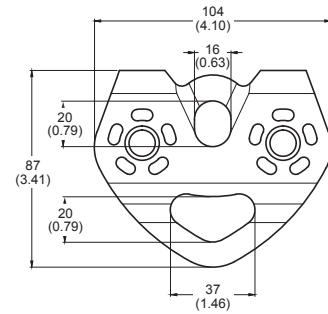
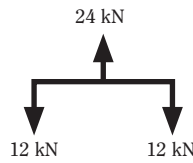

Anodized

mm (inch)

**N-5340B
Tyrolean Pulleys**

With Ball Bearing
With Stainless Sheave
Stamping aluminum alloy
Rope size : Maximum to 13 mm
Min. Breaking load : 24 kN
Net weight : 12.63 oz. / 358 g

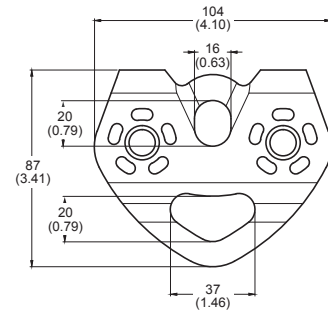
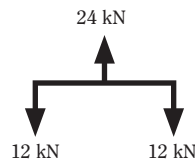

Anodized

mm (inch)

N-5320
Fixed Pulley

Stamping aluminum alloy
Rope size : Maximum to 12 mm
Min. breaking load : 20 kN
Net weight : 3.1 oz. / 88 g

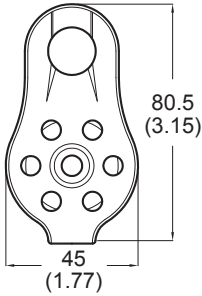

Anodized

mm (inch)

N-5322
Mobile Pulley

Stamping aluminum alloy
Rope size : Maximum to 12 mm
Min. breaking load : 20 kN
Net weight : 4.1 oz. / 117 g

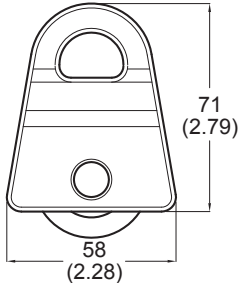

Anodized

mm (inch)

N-5330
Mobile Pulley

Stamping aluminum alloy
Rope size : Maximum to 16 mm
Min. breaking load : 30 kN
Net weight : 9.6 oz. / 272 g

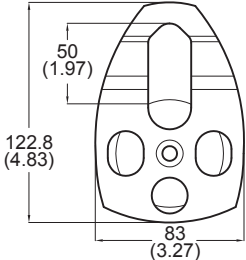

Anodized

mm (inch)

N-5332
Mobile Double Pulley

Stamping aluminum alloy
Rope size : Maximum to 16 mm
Min. breaking load : 30 kN
Net weight : 16.8 oz. / 476 g

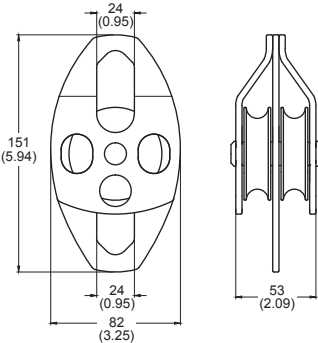

Anodized

mm (inch)

N-5300
Handled Ascender - Right Hand

Stamping aluminum alloy
Rope size : 9 mm to 12mm
● Meets : EN 567
Net weight : 6.9 oz. / 196 g

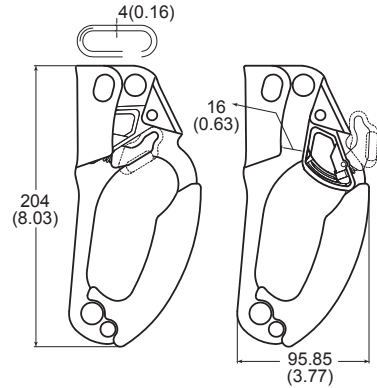

mm (inch)

Anodized

N-5302
Handled Ascender - Left Hand

Stamping aluminum alloy
Rope size : 9 mm to 12mm
● Meets : EN 567
Net weight : 6.9 oz. / 196 g

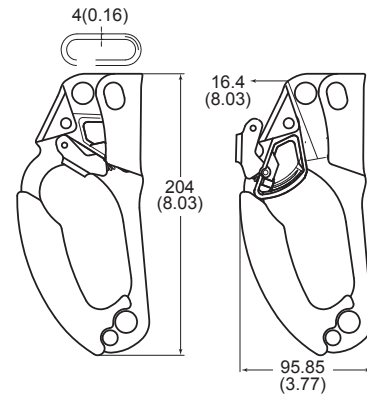

mm (inch)

Anodized

N-5306
Chest Ascender

Stamping aluminum alloy
Rope size : 9 mm to 12mm
● Meets : EN 567
Net weight : 5.8 oz. / 165 g

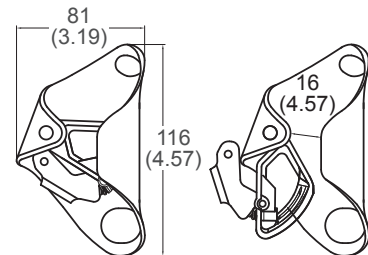

mm (inch)

Anodized

N-5350
Swivel

Forged aluminum alloy
Min. breaking load : 6000 lbs / 30 kN
Net weight : 5.6 oz. / 158 g



N-5350B

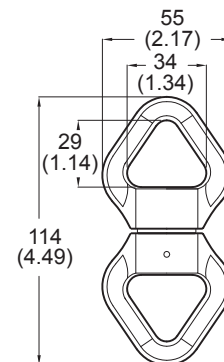

mm (inch)

N-5350B
Swivel With Ball Bearing

Forged aluminum alloy
Min. Breaking load : 6000 lbs / 30kN
Net weight : 5.7 oz. / 163 g

Anodized

N-5310
Belay Tube

Forged aluminum alloy
Rope size : 8 mm to 11 mm
Net weight : 2.0 oz. / 58 g

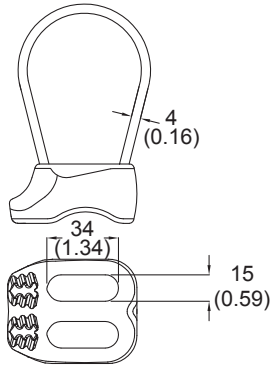

Anodized

mm (inch)

N-5312
Belay Tube

Forged aluminum alloy
Rope size : 8 mm to 11 mm
Net weight : 1.9 oz. / 53 g

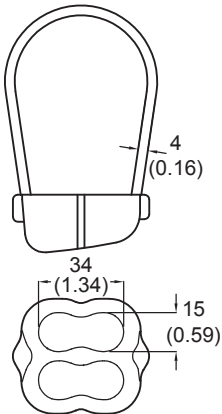

Anodized

mm (inch)

N-2301-CP
Aluminum Carabiner

Aluminum alloy
Min. Breaking load : 1800lbs / 8kN
Net weight : 1.02 oz. / 24 g

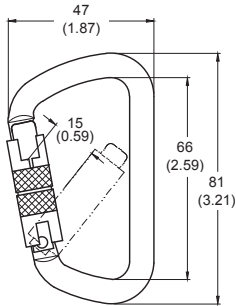

Anodized

mm (inch)

N-220
Forged Accessory Hook

Aluminum alloy
Min. breaking load : 5kN
Net weight : 0.7 oz. / 20 g

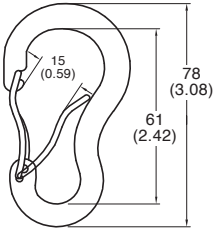

Anodized

mm (inch)

**N-5380
Rigging Plate**

Forged aluminum alloy
Min. breaking load : 35 kN
Net weight : 2.3 oz. / 65 g

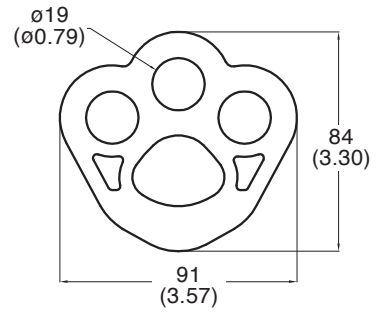

Anodized

mm (inch)

**N-5381
Rigging Plate**

Forged aluminum alloy
Min. breaking load : 35 kN
Net weight : 7.7 oz. / 220 g

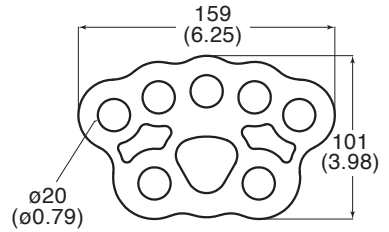

Anodized

mm (inch)

**N-5382
Rigging Plate**

Forged aluminum alloy
Min. breaking load : 45 kN
Net weight : 16.1 oz. / 460 g

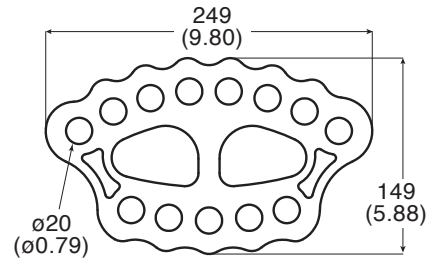

Anodized

mm (inch)

N-505
Figure 8 Descender

Forged aluminum alloy
For Rope : 3 / 8 " - 5 / 8 " (9 - 16 mm)
Min. Breaking load : 7500 lbs / 35 kN
Net weight : 4.1 oz. / 116 g

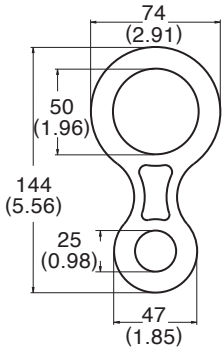

Anodized

mm (inch)

N-5052
Figure 8 Descender

Forged aluminum alloy
For Rope : 3 / 8 " - 5 / 8 " (9 - 16 mm)
Min. Breaking load : 5500 lbs / 25 kN
Net weight : 3.5 oz. / 100 g

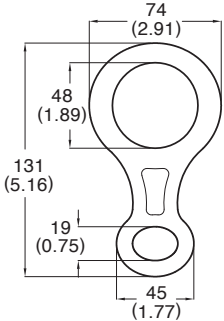

Anodized

mm (inch)

N-506
Big Figure 8 Descender

Forged aluminum alloy
For Rope : 3 / 8 " - 5 / 8 " (9 - 16 mm)
Min. breaking load : 9000 lbs / 40 kN
Net weight : 9.5 oz. / 270 g

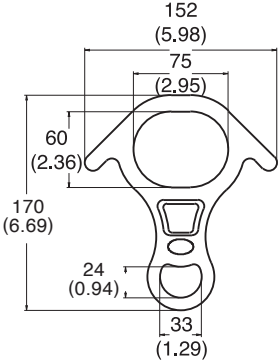

Anodized

mm (inch)

N-4506
Big Figure 8 Descender

Steel
For Rope : 3 / 8 " - 5 / 8 " (9 - 16 mm)
Min. breaking load : 11000 lbs / 50 kN
Net weight : 24.2 oz. / 691 g

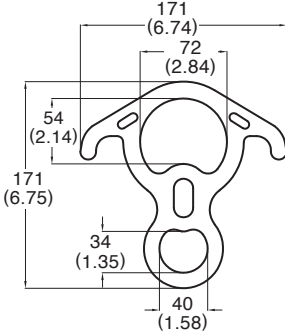

Zinc Plated

mm (inch)

S-7786-16
Rigging Screw Jaw and Stud

Stainless steel, SUS 316
 For wire rope : 8mm (5 / 16")
 Net weight : 32.0 oz. / 908 g

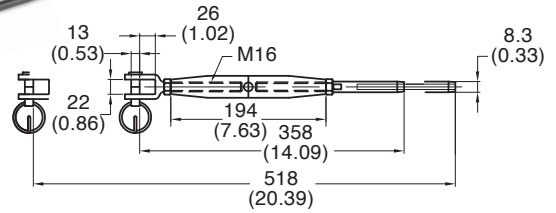

Polished

mm (inch)

S-7789-16
Rigging Screw Stud and Stud

Stainless steel, SUS 316
 For wire rope : 8mm (5 / 16")
 Net weight : 30.0 oz. / 850 g

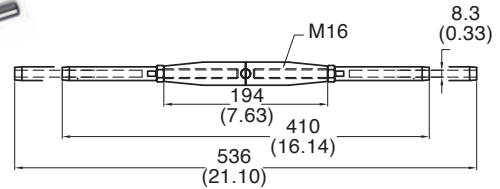

Polished

mm (inch)

S-7801-16
Swage Stud (right thread)

Stainless steel, SUS 316
 For wire rope : 8mm (5 / 16")
 Net weight : 9.0 oz. / 256 g

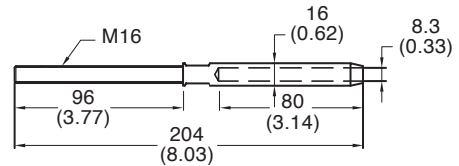

Polished

mm (inch)

S-7802-08
Eye Swage Stud

Stainless steel, SUS 316
 For wire rope : 8mm (5 / 16")
 Net weight : 3.4 oz. / 95 g

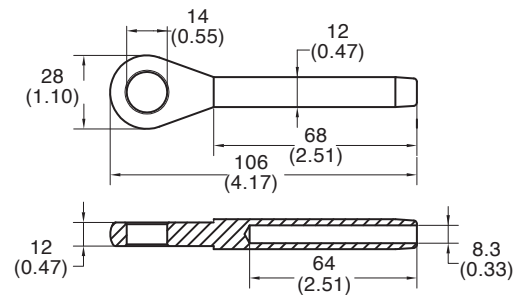

Polished

mm (inch)

S-7805-08
Jaw Swage Stud

Stainless steel, SUS 316
 For wire rope : 8mm (5 / 16")
 Net weight : 7.9 oz. / 223 g

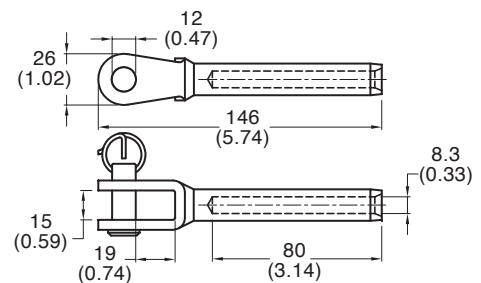

Polished

mm (inch)

N-704
Plastic shoulder pad

Colored : Black
Net weight : 1.8 oz. / 51 g

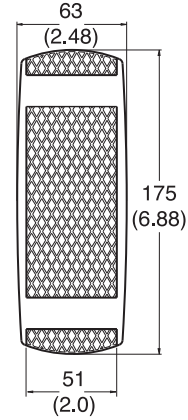

mm (inch)

N-703
Plastic Back pad

Net weight : 2.9 oz. / 83 g

Art. No.	Color
N-703.black	Black
N-703.red	Red
N-703.blue	Blue
N-703.yellow	Yellow
N-703.trans	Transparent

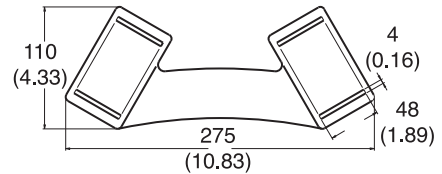

mm (inch)

N-701
Plastic Back pad

Net weight : 1.5 oz. / 44 g

Art. No.	Color
N-701.black	Black
N-701.red	Red
N-701.blue	Blue
N-701.yellow	Yellow

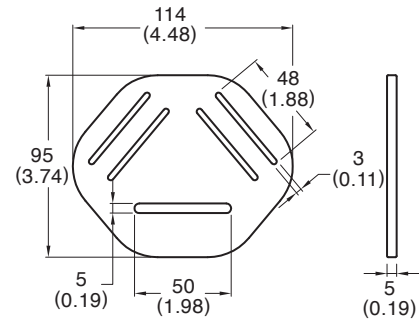

mm (inch)

N-Roller01 / N-Roller02 / N-Roller03 / N-Roller04 / N-Roller05 / N-Roller06 / N-Roller07
Plastic Roller

Art No.	A. Inner Dimension (Ø)	B. Overall Length (mm)
N-Roller01	10	25
N-Roller02	10	51
N-Roller03	12	42
N-Roller04	12	51
N-Roller05	12	65
N-Roller06	12	75
N-Roller07	15	49

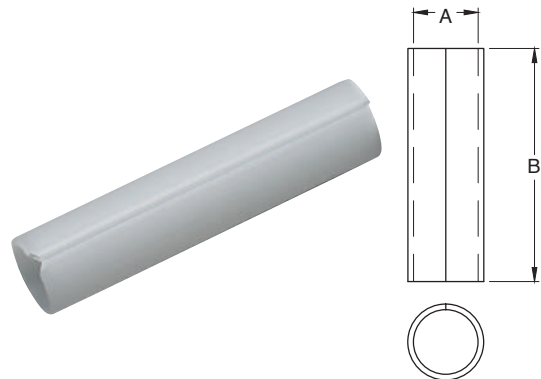

N-710
Plastic Back pad

Net weight : 0.80 oz. / 22 g

Art. No.	Color
N-710.black	Black
N-710.red	Red
N-710.blue	Blue
N-710.yellow	Yellow

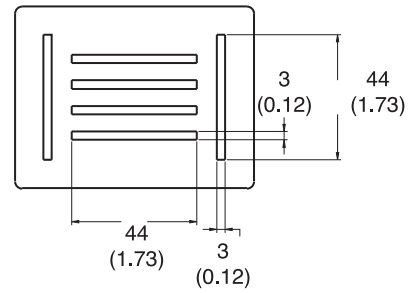
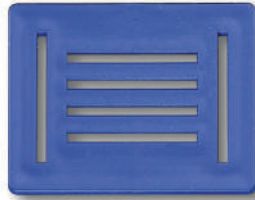

mm (inch)

N-705
Plastic Pad Black

Net weight : 0.4 oz. / 10 g

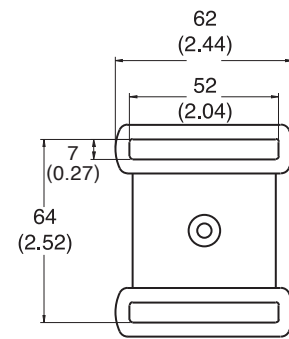

mm (inch)

N-706
Plastic Keeper

Net weight : 0.3 oz. / 9 g

Art. No.	Color
N-706.black	Black
N-706.red	Red
N-706.blue	Blue
N-706.yellow	Yellow

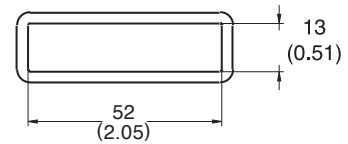

mm (inch)

N-707
Plastic Back pad

Net weight : 0.1 oz. / 3.5 g

Art. No.	Color
N-707.black	Black
N-707.red	Red
N-707.blue	Blue
N-707.yellow	Yellow

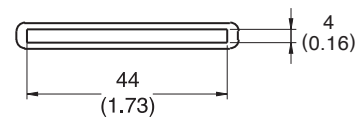

mm (inch)

**N-410
Plastic Thimble**

Net weight : 0.2 oz. / 7 g

Art. No.	Color
N-410.white	White
N-410.red	Red
N-410.blue	Blue
N-410.black	Black

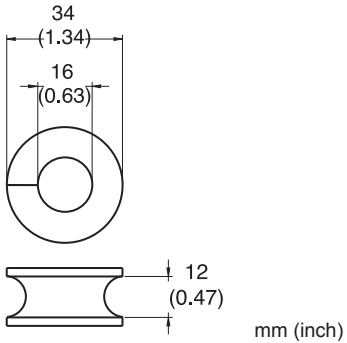

**N-4101
Brass Thimble**

Net weight : 0.21 oz. / 6 g

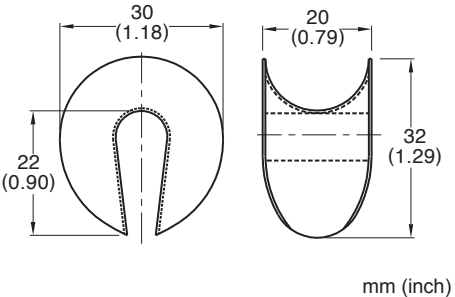

**N-708
Plastic Protector Sleeve**

Net weight : 0.5 oz. / 15 g

Art. No.	Color
N-708.black	Black
N-708.red	Red
N-708.blue	Blue
N-708.yellow	Yellow

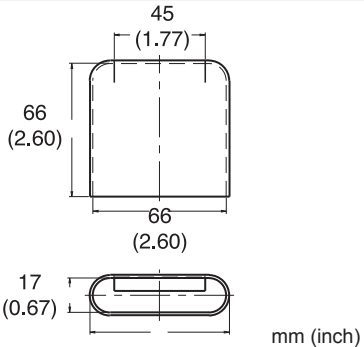

**N-709
Plastic Protector Sleeve**

Net weight : 0.56 oz. / 16 g

Art. No.	Color
N-709.black	Black
N-709.red	Red
N-709.blue	Blue
N-709.yellow	Yellow

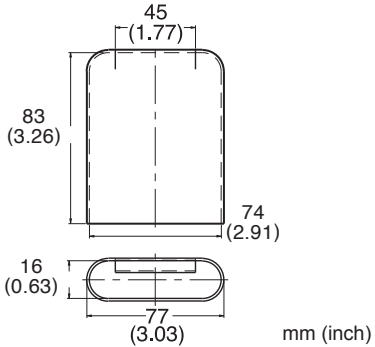

**N-482
Double Lockout Jaw**

Net weight : 4.1 oz. / 117 g

Red Painted.

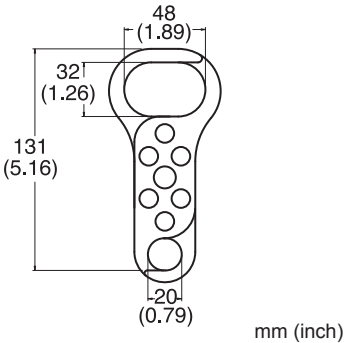

N-252GM-CP
Geomet Carabiner
3600 LBS gate strength

Steel Carabiner
 Alloy steel, heat treated
 100% proof loaded to 3600 lbs / 16kN
 Min. Breaking load : 5000 lbs / 23 Kn
 Meets :
 ● ANSI Z359.12-2019
 ● CSA Z259.12-16
 ● EN 362 : 2004
 Net weight : 8.96 oz. / 254 g
Geomet

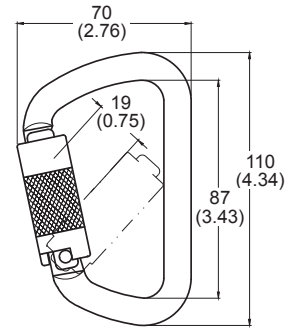

mm (inch)

N-248GL
Lifting Carabiner

Alloy steel, heat treated
 Net weight : 10.7 oz. / 303 g.
 Working Load Limit 2500 lbs
 Safety Factor 4 : 1
 For Material Handling

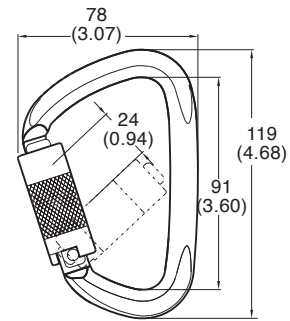

mm (inch)

Zinc Plated

N-483-ZN
O Ring

Forged steel, heat treated
 100% proof loaded to 3600 lbs / 16 kN
 Min. Breaking load : 5000 lbs / 23 kN
 Meets :
 ● ANSI Z359.12-2019
 ● CSA Z259.12-16
 ● Net weight : 5.2 oz. / 148 g



500 Hours Salt Spray

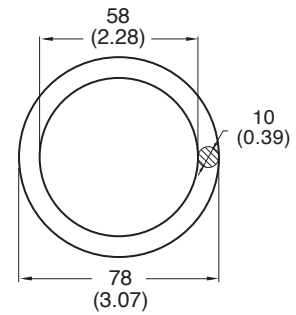

mm (inch)

Zinc Nickel

7350-08
Quick Link

Steel
 Net weight : 2.82 oz. / 80g

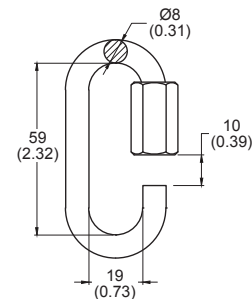

mm (inch)

Zinc Plated

**7355-08
Delta Link**

Steel
Net weight : 3 oz. / 85g

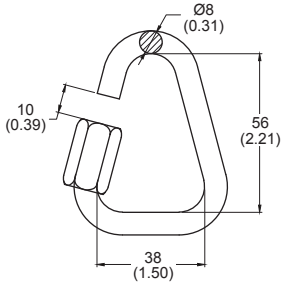

Zinc Plated

mm (inch)

**N-980
Anchor Point**

Material	Art No.	Net Weight	Ø
Steel	N-980-10	1.9 oz./55 g	10
	N-980-12	2.0 oz./58 g	12
Stainless Steel	N-980-S-10	1.8 oz./50 g	10
	N-980-S-12	1.9 oz./53 g	12

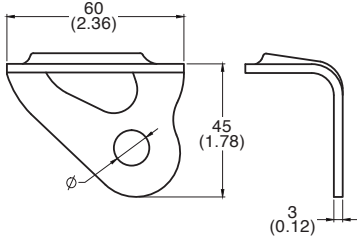

Polished

mm (inch)

A. Revolutionary Solution For Safety Inspection

YOKE's unique design of proprietary wafer-antenna chip construction, enables Smart Phone NFC and RFID inspection management to be more intuitive and efficient.

B. Benefits of Hardware Integrated RFID

- RFID chip INTEGRATED onto hardware
- Non-removable
- Easily Identifiable and Readable
- Product Traceability
- Every products has unique ID number
- By using RFID chip with a third-party asset management application to achieve product traceability, manufacturer authentication and digitised product information

C. RFID Tag Information

- Material: Nylon
- Size: 6mm
- Frequency: HF-13.56MHz ±3%
- Read Range: 8mm, depends on Reader type
- Standard : ISO 15693

D. Supports Multiple Reader Platforms

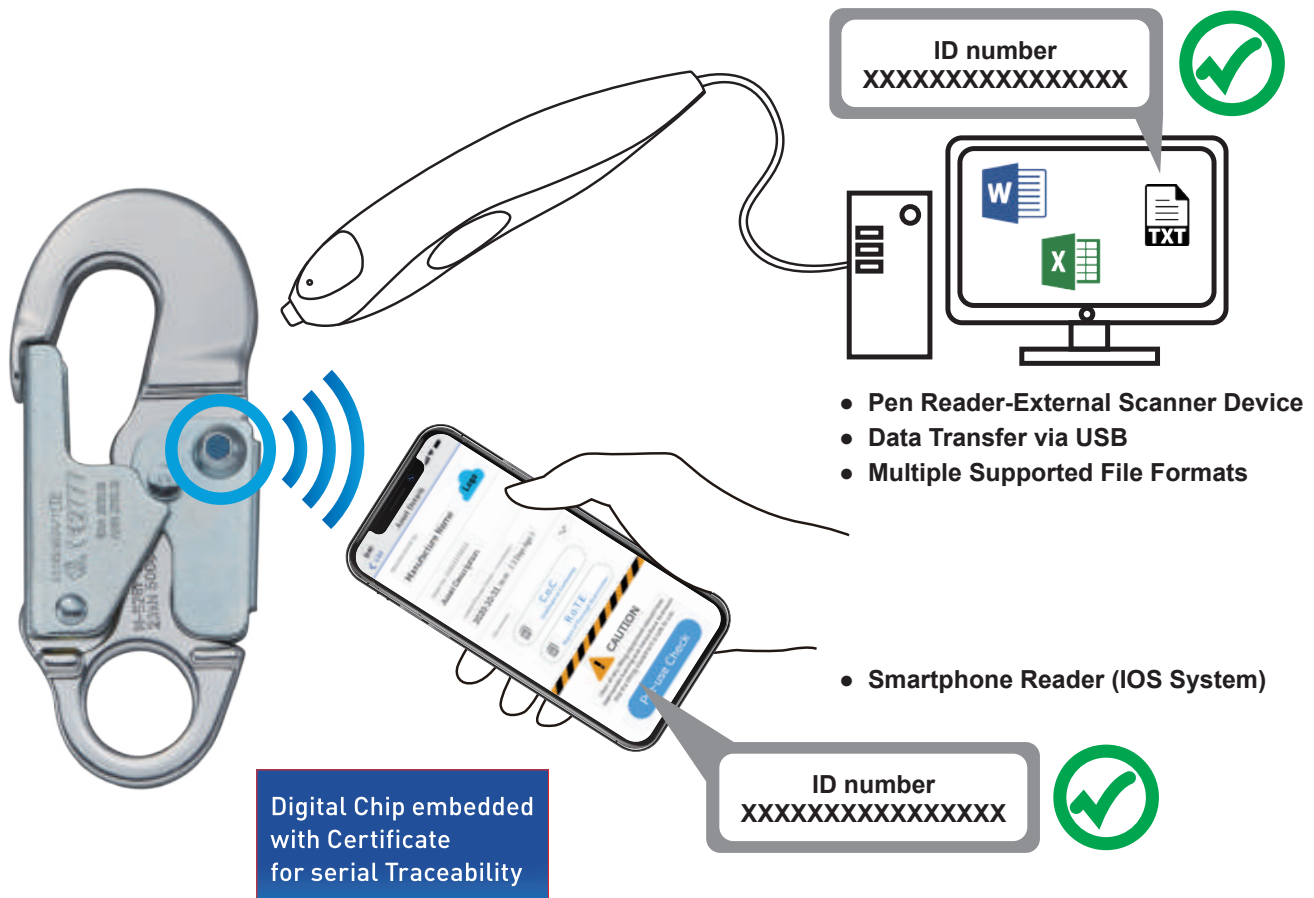

N-3610-Ri
Rope Snap Hook
3600 LBS gate strength

Forged steel, heat treated
 100% proof loaded to 3600 lbs / 16 kN
 Min. Breaking load : 5000 lbs / 23 kN
 Meets :
 ● ANSI Z359.12-2019
 ● CSA Z259.12-16
 ● EN 362 : 2004
 Net weight : 13.6 oz. / 388 g
Zinc Plated

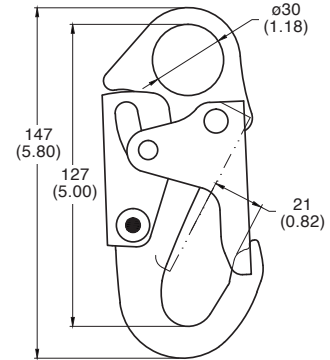

mm (inch)

N-3615-Ri
Indicator Swivel Hook
3600 LBS gate strength

Forged steel, heat treated
 100% proof loaded to 3600 lbs / 16 kN
 Min. Breaking load : 5000 lbs / 23 kN
 Meets :
 ● ANSI Z359.12-2019
 ● CSA Z259.12-16
 ● EN 362 : 2004
 Net weight : 17.5 oz. / 501 g
 Indicator Strength Options: ① 500 lbs ② 750 lbs
Zinc Plated

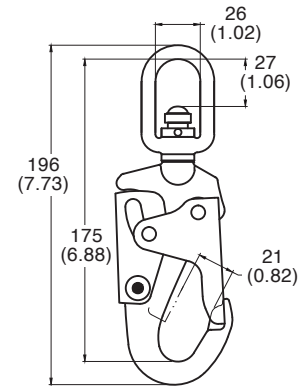

mm (inch)

N-3630T-Ri
Rebar Hook
3600 LBS gate / Transverse Load

Forged steel, heat treated
 100% proof loaded to 3600 lbs / 16 kN
 Min. Breaking load : 5000 lbs / 23 kN
 Meets :
 ● ANSI Z359.12-2019
 ● CSA Z259.12-16
 ● EN 362 : 2004
 Net weight : 28.5 oz. / 800 g
Zinc Plated

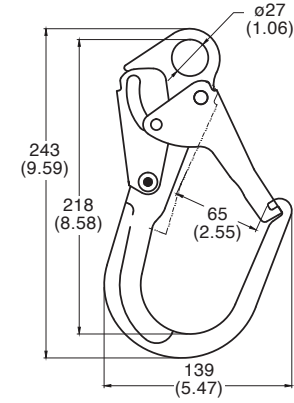

mm (inch)

N-314-Ri
Rebar Hook

Designed for 2" or small rebar
 Forged steel, heat treated
 Min. Breaking load : 5000 lbs / 23 kN
 Meets :
 ● EN 362 : 2004
 Net weight : 17.6 oz. / 500 g
Zinc Plated

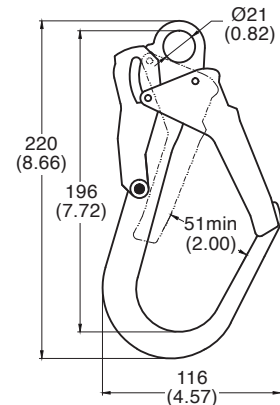

mm (inch)

N-5261-Ri
Aluminum Snap Hook
3600 LBS gate strength

Forged aluminum alloy
100% proof loaded to 3600 lbs / 16 kN
Min. Breaking load : 5000 lbs / 23 kN
Meets :

- ANSI Z359.12-2019
- CSA Z259.12-16
- EN 362 : 2004

Net weight : 8.7 oz. / 247 g

Anodized

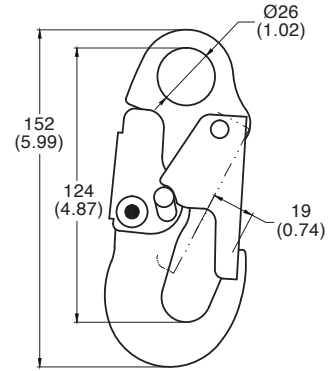

mm (inch)

N-5271T-Ri
Aluminum Rebar Hook
3600 LBS gate/Transverse Load

Forged aluminum alloy
100% proof loaded to 3600 lbs / 16kN
Min. Breaking load : 5000 lbs / 23 kN
Meets :

- ANSI Z359.12-2019
- CSA Z259.12-16
- EN 362 : 2004

Net weight : 22.3 oz. / 637 g

Anodized

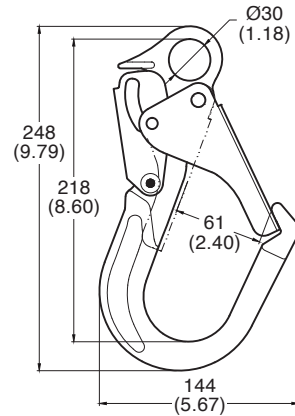

mm (inch)

N-50130-Ri
Aluminum Rebar Hook

Forged aluminum alloy
Min. Breaking load : 5000 lbs / 23 kN
Meets :

- EN 362 : 2004

Net weight : 16.8 oz. / 480 g

Anodized

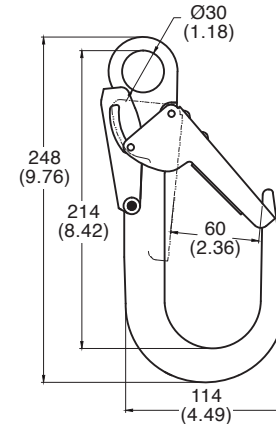

mm (inch)

N-415-Ri
Stamped D-Ring

Stainless steel, SUS 304
100% proof loaded to 3600 lbs / 16 kN
Min. Breaking load : 5000 lbs / 23 kN
Meets :

- ANSI Z359.12-2019

Net weight : 5.0 oz. / 142 g

Polished

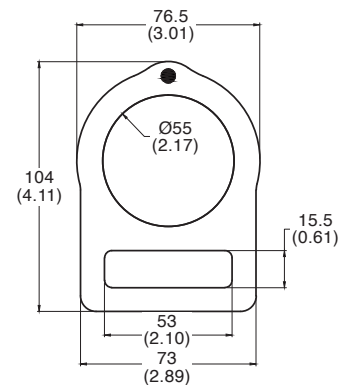

mm (inch)

**N-416L-Ri
D-Ring**

Forged steel, heat treated
 100% proof loaded to 3600 lbs / 16 kN
 Min. Breaking load : 5000 lbs / 23 kN
 Meets :
 ● ANSI Z359.12-2019
 Net weight : 4.2 oz. / 120 g

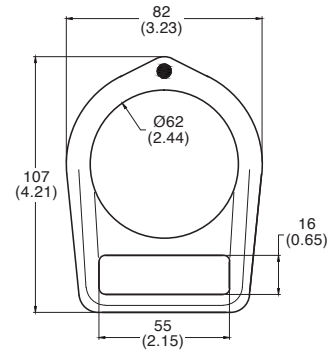

mm (inch)

Zinc Plated

**N-416-Ri
D-Ring**

Forged steel, heat treated
 100% proof loaded to 3600 lbs / 16 kN
 Min. Breaking load : 5000 lbs / 23 kN
 Meets :
 ● ANSI Z359.12-2019
 Net weight : 5.0 oz. / 142 g

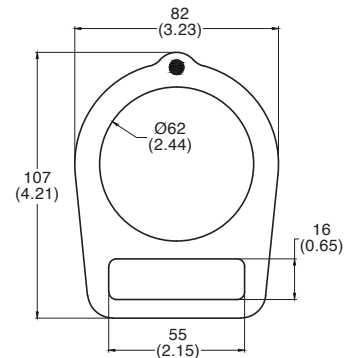

mm (inch)

Zinc Plated

**N-529-Ri
Aluminum Bent D-Ring**

Forged aluminum alloy
 100% proof loaded to 3600 lbs / 16 kN
 Min. Breaking load : 5000 lbs / 23 kN
 Meets :
 ● ANSI Z359.12-2019
 Net weight : 2.8 oz. / 78 g

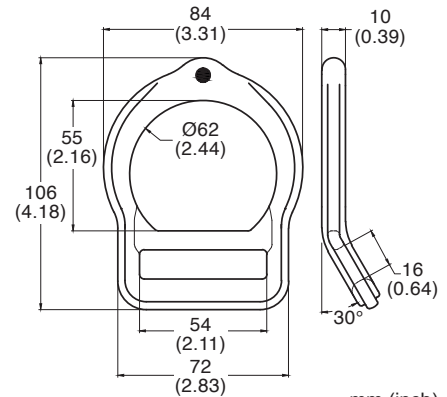

mm (inch)

Anodized

**N-528-Ri
Aluminum D-Ring**

Forged aluminum alloy
 100% proof loaded to 3600 lbs / 16 kN
 Min. Breaking load : 5000 lbs / 23 kN
 Meets :
 ● ANSI Z359.12-2019
 Net weight : 2.6 oz. / 75 g

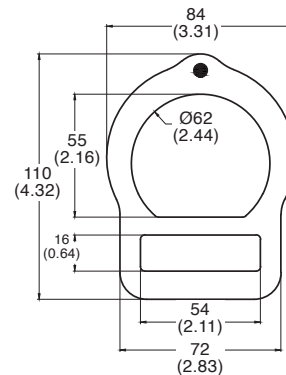

mm (inch)

Anodized

INDEX

Item No.	Page	Item No.	Page	Item No.	Page	Item No.	Page	Item No.	Page	Item No.	Page	Item No.	Page
7350-08	138	N-3040-1	13	N-402	32	N-431	29	N-50130	62	N-5380	132	N-707	136
7355-08	139	N-3041	13	N-4021L	30	N-431-S	79	N-50130-Ri	143	N-5381	132	N-708	137
N-220	131	N-3049	14	N-402-S	78	N-432	29	N-5015	63	N-5382	132	N-709	137
N-2301-CP	131	N-3056	12	N-402W	32	N-432A-S	78	N-5015/0	63	N-540	67	N-710	136
N-244-0-S	81	N-3058	13	N-403	27	N-432-S	78	N-5018	63	N-5407	69	N-800	117
N-244G	85	N-3059	13	N-403L	27	N-433	42	N-5019	69	N-5407B	69	N-8232050A	119
N-245G	87	N-306	10	N-403-S	78	N-4335	47	N-502	61	N-5416	67	N-8232050B	119
N-246G	88	N-314-MX	17	N-403XL	27	N-433L	42	N-5020	69	N-5439	72	N-8232050W	120
N-247G-CP	90	N-314-Ri	142	N-404	32	N-434	38	N-503	65	N-5719	70	N-8232100A	119
N-248G	89	N-315	10	N-404R	32	N-435	39	N-5032	65	N-5720	70	N-8232100B	119
N-248GL	138	N-3155	14	N-4052	30	N-436	41	N-5035	65	N-5721	70	N-8232100TB	121
N-250G	85	N-315X	10	N-4053	25	N-437	24	N-5035 / 0	65	N-5722	70	N-8232100W	120
N-250GK	85	N-3161	14	N-406	33	N-439	49	N-504	61	N-5740	71	N-86050	117
N-251G	87	N-3167	11	N-407	31	N-439X	49	N-505	133	N-5741	71	N-8611	117
N-252G	86	N-3167 / 0	11	N-407L	30	N-440	49	N-5051	64	N-5742	71	N-8S232050A	121
N-252GK	86	N-325 / 0	18	N-407R	31	N-441	49	N-5052	133	N-5748	71	N-8S232050B	121
N-252GM-CP	138	N-326	17	N-408	31	N-442	36	N-506	133	N-5860	76	N-8S232050WA	121
N-252-S	81	N-331	61	N-408R	31	N-443	45	N-507	68	N-5861	76	N-903	122
N-254G	88	N-339	61	N-409	21	N-445	28	N-5072F	123	N-5862	76	N-904	122
N-256G	86	N-350	124	N-410	137	N-445L	28	N-5072R	123	N-5867	77	N-904-S	77
N-258G-CP	90	N-3501	124	N-4101	137	N-448	43	N-5077	117	N-5868	74	N-905	122
N-259G-CP	91	N-3502	124	N-411	46	N-448-S	80	N-508	72	N-5868T	74	N-907	122
N-2615G	89	N-351	125	N-412	44	N-449	33	N-509	72	N-5869	75	N-908	118
N-261G	89	N-3512	127	N-413	41	N-4501	39	N-510	72	N-5869-DA	75	N-980	139
N-263G-CP	90	N-352	125	N-4135	41	N-4502	40	N-511	72	N-5869T	74	N-DE001	52
N-265G-CP	91	N-353	125	N-413X	41	N-4506	133	N-512	68	N-5870A	75	N-DE002	52
N-267G	88	N-354	125	N-414	21	N-451	40	N-51428	73	N-5871	75	N-DE005	55
N-268G	87	N-355	126	N-414R	21	N-452	42	N-51445	73	N-5876	76	N-DE006	55
N-268G-S	81	N-356	126	N-414-S	79	N-452L	42	N-51445A	73	N-5877	74	N-DE007	54
N-270	97	N-357	126	N-414X	21	N-453	34	N-51460	73	N-602	111	N-DE008	54
N-271	94	N-358	126	N-415	22	N-455	24	N-518	67	N-602-12	111	N-DE009	54
N-272	96	N-3591-S	77	N-415R	22	N-459	124	N-519	67	N-604	113	N-DE244-0	51
N-273	97	N-360	18	N-415-Ri	143	N-460	25	N-5203	68	N-606AP	111	N-DE300	51
N-274	96	N-3610	7	N-415-S	79	N-461	25	N-5204	68	N-608	115	N-DE301	51
N-275	97	N-3610-Ri	142	N-415X	22	N-469	25	N-5212	73	N-608AL	115	N-DE360	51
N-2750	99	N-3610-S	82	N-416	20	N-475	33	N-5246	60	N-609	115	N-DE403	52
N-276	96	N-3615	8	N-416L	20	N-476	24	N-5248	60	N-610	108	N-DE403B	52
N-277	98	N-3615-Ri	142	N-416L-R	20	N-476R	24	N-5261	59	N-610LY	108	N-DE415	53
N-278	98	N-3615-S	82	N-416L-Ri	144	N-477	23	N-5261-Ri	143	N-616	109	N-DE415B	53
N-281	94	N-3616	8	N-416R	20	N-478	26	N-5265	60	N-617	109	N-DE420	56
N-2817	118	N-3616-S	82	N-416-Ri	144	N-479	48	N-5265 / 0	60	N-618	110	N-DE4207	56
N-282	95	N-3617	8	N-417	23	N-4793	48	N-5268	59	N-619	110	N-DE422	56
N-283	95	N-3618	8	N-418	22	N-4795	48	N-5271T	59	N-619T	110	N-DE448	56
N-284	95	N-3620T	16	N-419	23	N-4797	48	N-5271T-Ri	143	N-620	112	N-DE452	57
N-2852	99	N-3625T	16	N-419R	23	N-480	124	N-5275T	59	N-621	112	N-DE460	53
N-2852G	104	N-3625T/0	17	N-420	38	N-4805	124	N-528	66	N-622	112	N-DE460B	53
N-2853G	104	N-3630T	15	N-4201	38	N-481	123	N-528A	66	N-623	112	N-DE483	54
N-2854	99	N-3630TF	15	N-4203	39	N-481R	123	N-528-Ri	144	N-626	112	N-DE518	55
N-2854G	104	N-3630T-Ri	142	N-4206	38	N-482	137	N-529	66	N-630	108	N-DE529	55
N-2855	100	N-3633T	15	N-4207	40	N-483	34	N-529A	66	N-630LY	108	N-RCT27337	9
N-2855G	105	N-3633T/0	16	N-420-S	79	N-483-ZN	138	N-529-Ri	144	N-636	109	N-Roller01	135
N-2857	100	N-3633TF/0	16	N-421	39	N-485	123	N-5300	130	N-637	109	N-Roller02	135
N-2857 / 0	100	N-3658	9	N-421-S	80	N-486	34	N-5302	130	N-638	110	N-Roller03	135
N-2857 / OG	105	N-3660	9	N-422	35	N-487	34	N-5306	130	N-639	111	N-Roller04	135
N-2857G	105	N-3680	17	N-4224	35	N-489	35	N-5310	131	N-650	113	N-Roller05	135
N-2859	101	N-3710	7	N-4226	35	N-4910	44	N-5312	131	N-650B	113	N-Roller06	135
N-2859G	106	N-3810	7	N-422-S	80	N-4911	44	N-5320	129	N-651	113	N-Roller07	135
N-2868G	106	N-3810X	7	N-423	43	N-4912	44	N-5322	129	N-651B	114	Puck & Bolt	120
N-2868GL-CP	106	N-3830T	15	N-4237	43	N-492	26	N-533	73	N-652	114	S-7786-16	134
N-287	98	N-400	46	N-423-S	80	N-492-BT	27	N-5330	129	N-660	114	S-7789-16	134
N-3032	10	N-400 / S	46	N-424	43	N-493	26	N-5331	127	N-668	112	S-7801-16	134
N-3033	12	N-4001	46	N-425	47	N-493-BT	26	N-5331B	127	N-670	114	S-7802-08	134
N-3035	11	N-401	36	N-426	47	N-4940-BZP	45	N-5332	129	N-6901	128	S-7805-08	134
N-3035 / 0	11	N-4011	36	N-427	47	N-4941	45	N-5340	128	N-701	135		
N-3035M	127	N-4012	36	N-428	37	N-500	62	N-5340B	128	N-703	135		
N-3036	14	N-4013	37	N-429	33	N-501	62	N-5350	130	N-704	135		
N-3039	12	N-4014	37	N-430	29	N-501110	62	N-5350B	130	N-705	136		
N-3040	12	N-4016	37	N-430-S	77	N-501110X	63	N-5372	127	N-706	136		



YOKE INDUSTRIAL CORP.

#39, 33rd Road, Taichung Industrial Park,

Taichung 407, TAIWAN

Tel : +886-4-2350-8088

Fax : +886-4-2350-1001

E-mail : info@mail.yoke.net

[http : // www.yoke.net](http://www.yoke.net)



An ISO 9001 Certified Company